

IDM UID

8ZUZWA

VERSION CREATED ON / VERSION / STATUS

27 Jun 2023 / 1.1 / Approved

EXTERNAL REFERENCE / VERSION

Technical Specifications (In-Cash Procurement)

Technical specifications for MCTB Cryostat

This document describes the summary Technical specification for MCTB (Magnet Cold Test Bench) Cryostat

1. Introduction	3
2. Scope of supply.....	3
2.1. Description of the procurement	3
2.2. Components to be supplied.....	3
3. Design requirements	3
3.1. Functional requirements	3
3.2. System requirements.....	3
3.3. Interface requirements.....	4
4. Timescale	4

Definitions

Abbreviation	Definition
ANB	Agreed Notified Body
ASN	Autorité de Sécurité Nucléaire
BoM	Bill of Material
CMA	Construction Management as Section/Division
DWG	Drawing
TF	Toroidal Field
PF	Poloidal Field
ESPN	Équipements Sous Pression Nucléaires –Nuclear Pressure Equipment
GMS	General Management Specification
IO	ITER Organisation
ITP	Inspection and Test Plan
MIP	Manufacturing and Inspection Plan
N/A	Not Applicable
NDE	Non-Destructive Examination
NDT	Non-Destructive Testing
PIA	Protection Important Activity
PIC	Protection Important Component
PBS	Plant Breakdown Structure
VV	Vacuum Vessel
HEL	Highly Exceptional Loads
PDR	Preliminary design review
FDR	Final Design Review
MLI	Multi Layer Insulation

1. Introduction

ITER is a joint international research and development project that aims to demonstrate the Scientific and technical feasibility of fusion power. The partners in the project - the ITER Parties - are the European Union, Japan, the People's Republic of China, India, the Republic of Korea, the Russian Federation and the USA. ITER is now under construction in Europe, at Cadarache, South of France. For details see www.iter.org.

A facility to test the ITER superconducting TF and PF-1 magnets is under development. A cryostat is required for housing the magnet in vacuum environment for the test at cryogenic temperature. The purpose of this document is to provide the preliminary technical specifications required for the supplier to provide an interest and the estimated quotation for the final design, manufacturing & factory acceptance testing & support/ guidance for the site installation and site acceptance testing of the cryostat.

2. Scope of supply

2.1. Description of the procurement

The scope will include the Cryostat detail and manufacturing design, the manufacturing, factory acceptance, packing and shipment to FOS harbour, support services during the site installation activities of cryostat.

2.2. Components to be supplied

Sr. no.	Component
1	Cryostat
2	Internal Magnet Support Structure
3	MLI for Thermal Shielding
4	Assembly Tools and Frames

3. Design requirements

3.1. Functional requirements

The Cryostat shall provide an enclosure for the ITER Toroidal Field (TF) and Poloidal Field-1 (PF-1) magnet in order to perform testing under current at 4K temperature. The main functions of the Cryostat are to:

- Provide a vacuum environment to avoid excessive thermal loads (conductive, convective and radiative) from the outside environment to the magnets being tested at cold temperature
- Provide a mechanical support for the magnets

3.2. System requirements

The cryostat shall consist of an enclosure able to house the following main parts/components:

- TF magnet and PF magnet
- Internal support structure
- MLI for Thermal shielding
- Connections (pipes, busbars, feedthroughs etc.) for the interface systems

Note: The Cryostat design presented in this document is conceptual representation; contractor shall perform the final design with an optimized shape for the cryostat to accommodate the TF and PF-1 magnets.

The cryostat shall be made of Stainless steel type 304.

MLI shall be used for Thermal Shield.

The nominal vacuum level inside the cryostat at the start of operation shall be of the order of 10^{-3} Pa warm.

The cryostat shall be designed for multiple assembly and dis assembly cycles for magnet testing.

The loads from the cryostat shall be transferred to the floor through support legs.

A structure shall enable the mechanical support of the magnets inside the Cryostat. The deadweight of the approximately 350 tons shall be supported by 4 to 6 support legs.

The Cryostat shall include Pressure Relief Devices (PRDs) and man accesses allowing to enter the Cryostat without removing the leak tight cover.

The Cryostat shall be shipped to IO site in 01 part (with its dedicated transportation frame if needed) in order to minimize the assembly activities on site.

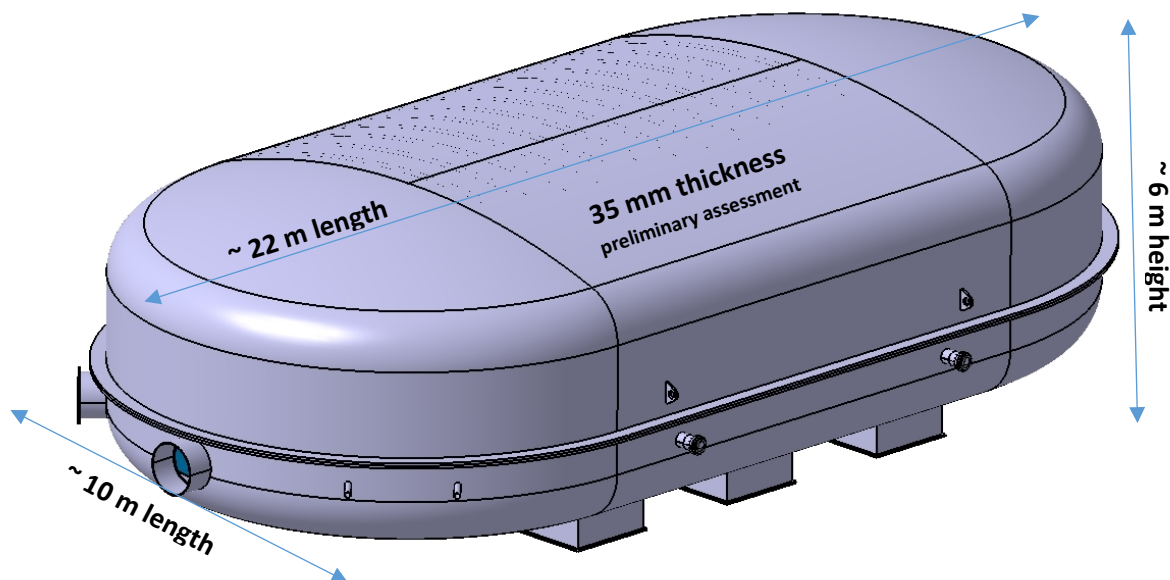

Figure 3-1 Conceptual Dimensions of Cryostat (contractor to perform own assessment for cryostat design)

3.3. Interface requirements

The cryostat shall provide ports/openings envisaged for vacuum pumping system, Magnet feeder connection, cryogenic system, instrumentation feedthroughs and man access.

The Cryostat shall include lifting interfaces in order to allow its alignment & handling during initial installation and the repetitive fitting and removal of the Cryostat cover during the magnet testing phases.

4. Timescale

The procurement process will start by Q3 – 2023 with contract award before end of 2023. The delivery schedule (including all project phases) of the cryostat to France harbour shall not exceed 18 months from the date of contract award.