

Technical Specifications (In-Cash Procurement)

Supply of LEVI Remote Handling Compatible electrical connectors

Supply Contract: The contractor is responsible for manufacturing and supply of Remote Handling (RH) electric connectors which are installed in the Diagnostic Shielding Module (DSM) for the diagnostic port plug. There are two different type of the RH electric connectors: Front-End connector which provides the electrical connection with the tenant system in the DSM, and DSM connector which connects the cables between the DSM to the PP.

The contractor is responsible for the supply of products and ...

Table of Contents

1	SUBJECT	3
1.1	RESPONSIBILITIES	3
1.2	CONTRACT EXECUTION	3
1.2.1	<i>Outline of Contract implementation</i>	3
1.2.2	<i>Time schedule</i>	4
1.2.3	<i>Estimated Duration</i>	4
1.2.4	<i>Binding contract requirements</i>	4
2	SCOPE OF SUPPLY	5
2.1	GENERAL	5
2.2	COMPONENTS NOT INCLUDED IN THE SCOPE OF WORK	8
2.3	MANUFACTURING OF THE COMPONENTS	9
2.4	FACTORY ACCEPTANCE TEST	9
2.5	PACKING AND DELIVERY	9
2.6	SUPPLY OF DOCUMENTATION	9
3	TECHNICAL REQUIREMENTS	9
3.1	DESCRIPTION	9
3.1.1	<i>DSM connector Assembly</i>	10
3.1.2	<i>FE Connector Assembly</i>	13
3.1.3	<i>Structural casing</i>	14
3.1.4	<i>Connector Modules</i>	14
3.1.5	<i>Insulator Assemblies</i>	17
3.2	MANUFACTURING DESIGN REQUIREMENTS	18
3.3	MATERIAL REQUIREMENTS.....	18
3.4	CODES AND STANDARDS.....	19
3.5	SYSTEM CLASSIFICATIONS	20
3.5.1	<i>Safety classification</i>	20
3.5.2	<i>Quality Assurance Classification</i>	20
3.5.3	<i>Vacuum classification</i>	20
3.5.4	<i>Classification according to PE/NPE French regulations</i>	20
3.6	CAD ACTIVITIES AND ENGINEERING DRAWINGS	20
3.7	MANUFACTURING REQUIREMENTS.....	20
3.7.1	<i>Machining and assembly requirement</i>	21
3.7.2	<i>Vacuum and Cleanliness requirement</i>	22
3.7.3	<i>Metrology and tolerances</i>	22
3.7.4	<i>Copper coating requirements</i>	22
3.7.5	<i>Ceramic coating requirements</i>	23
3.8	CE MARKINGS	24

4	DELIVERY	24
4.1	REQUIREMENTS FOR LABELLING, CLEANING, PACKAGING, HANDLING, SHIPMENT AND STORAGE	24
4.1.1	<i>Scope of application</i>	24
4.1.2	<i>Labelling and Traceability</i>	24
4.1.3	<i>Preservation of cleanliness</i>	24
4.1.4	<i>Storage Requirements</i>	25
4.1.5	<i>Packaging and Handling</i>	25
4.1.6	<i>Shipment, Transportation and Delivery to the IO site</i>	27
5	TESTING	27
5.1	EXAMINATION, INSPECTION AND TESTS	27
5.2	FINAL ACCEPTANCE TEST	28
5.2.1	<i>Dimensional inspection</i>	28
5.2.2	<i>Visual inspection</i>	28
5.2.3	<i>Electrical Tests</i>	28
5.2.4	<i>Mechanical test</i>	29
6	CONTRACT MANAGEMENT	29
6.1	CONTROL POINTS	30
6.2	DATA MANAGEMENT	30
6.3	REVIEWS	31
6.4	MONITORING AND ACCESS RIGHTS	31
7	QUALITY ASSURANCE	31
8	APPLICABLE AND REFERENCE DOCUMENTS	32
8.1	APPLICABLE DOCUMENTS	32
8.2	REFERENCE DOCUMENTS	32
9	ACRONYMS	33
10	LIST OF APPENDICES	33

1 Subject

Supply Contract: The contractor is responsible for manufacturing and supply of Remote Handling (RH) electric connectors which are installed in the Diagnostic Shielding Module (DSM) for the diagnostic port plug. There are two different type of the RH electric connectors: Front-End connector which provides the electrical connection with the tenant system in the DSM, and DSM connector which connects the cables between the DSM to the PP.

The contractor is responsible for the supply of products and their delivery to the IO (ITER Organization) Site, and for ensuring that the product meets the acceptance criteria defined in this Technical Specification.

1.1 Responsibilities

The responsibilities between the Parties is summarised in **Error! Reference source not found.** (below) and is further detailed in the following sections.

Table 1 Summary of responsibilities between the Client (IO) and the contractor

Activity	Client (IO)	Supplier
Manufacture, Assembly, FAT and Delivery		
Manufacturing Readiness Review (MRR)	A	R
Manufacturing batch#1	A	R
Manufacturing batch#2	A	R
Manufacturing batch#3	A	R
Factory Acceptance Testing	A	R
Packing and Delivery to the IO Site	A	R

R = Responsible for organizing, performing and for the content

A = Review/Comment/Accept/Approve

1.2 Contract execution

1.2.1 Outline of Contract implementation

The overall procurement cycle is divided into the following main phases:

- MRR input package preparation and MRR execution
- Manufacture of in-series final products
- Factory Acceptance Testing
- Delivery to the IO Site
- Testing at the IO Site
- Final Acceptance at the IO Site

The content and requirements of each phase is detailed in the following sections.

ITER_D_9SFDTC

1.2.2 Time schedule

The contractor shall produce a detailed Schedule showing all phases of the Contract and showing how the overall IO Schedule will be complied with. This detailed Schedule shall be submitted to the IO for approval/acceptance, before starting any work in relation to the Contract.

Target delivery dates for every set of items are those specified in Figure 1. It should be noted that the delivery schedule for Batch #2 & Batch #3 can be modified according to the overall IO schedule. Regardless of this schedule modification, the machining of sub-parts in Table 4 of Appendix 1 can proceed without interruption. It will impact only the schedule for the final assembly of Batch #2 and Batch #3.

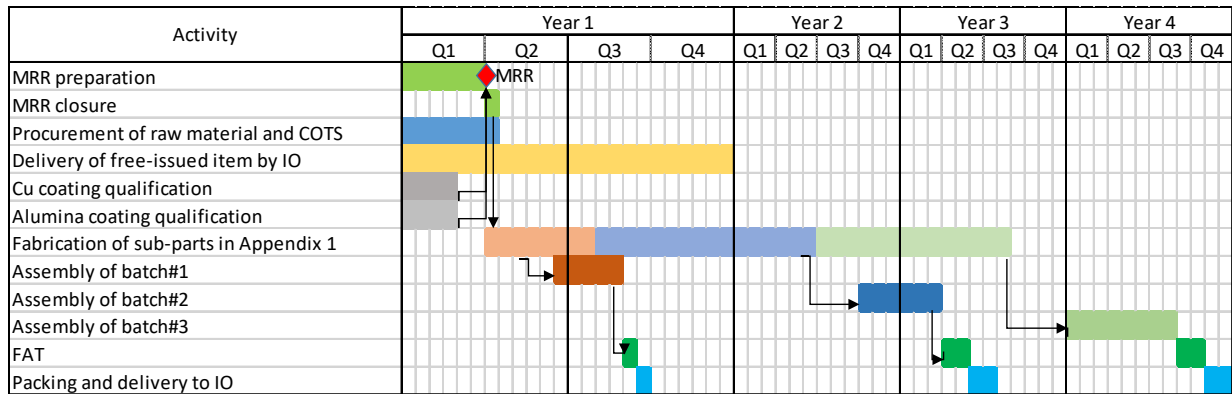

Figure 1 DSM and FE Connector delivery schedule

1.2.3 Estimated Duration

The contract will be carried out over an initial firm period of four (4) years.

1.2.4 Binding contract requirements

The binding contract requirements which the contractor shall comply with are described with the following two documents:

- Technical specification dedicated to this contract, which is described in this document
- General Management Specification for Service & Supply (“GM3S”) given in [AD2]

The GM3S is the reference document for the management of the scope that is to be performed in preparation for, and during the implementation of the Contract, in conjunction with the technical specification and the Contract conditions.

The GM3S presents the main principles and requirements which the Contractor must take into account during the implementation of the scope of work and defines the minimum standards expected for the management of the occupational health safety (“OHS”), environment, quality, contact control and all associated deliverables.

2 Scope of Supply

2.1 General

The contractor shall provide the IO with the following RH-compatible electric connector assemblies which will be installed to the diagnostic port plug:

- A pair of DSM (Diagnostic Shield Module) Connector Assembly composed of male and female part
- A pair of FE (Front-End) Connector Assembly composed of male and female part

The design of these connector assemblies are illustrated in Figure 2. Each male or female connector is composed of the following sub-components as shown in Figure 3 ~ Figure 6:

- Structural casing
- Modules
- Insulator assembly
- Contact pin or socket

The designs of these sub-components are standardized so that their final assembly of each connector can be configured depending on cable types and quantity to be connected. In other words, the structural casing is standardized depending of the type and number of modules to be installed and the other components are standardized for the type of cables to be connected. Depending on the number of modules, the FE connector has 6 size variations and the DSM connector has 2 size variations.

Table 2 shows the quantities for the DSM and FE connector assembly that the contractor shall supply. Each connector assembly in the table is a coupled pair of a male connector and a female connector. Each connector assembly will have a different configuration of modules, insulator assemblies and contact pins/sockets, depending on the cable configuration required. The 2D assembly drawing of each connector will be provided by IO.

Table 2 Classification and quantities of different DSM and FE connector assembly (one Unit is composed of a pair of male and female connector)

Pair of male/female connectors	Classification			Quantities				
	Quality	Safety	Vacuum	Batch#1 (EPP#1 1/12)	Batch#2 (UP2/4/5/6/ 7/8/18 & EP2/8/17)	Batch#3 (UP9/11/1 4 & EP3/9)	Spares	Total
FE Connector Assembly with 1 module	QC-1	Non-SIC	VQC-1B	6	23	13	4	46
FE Connector Assembly with 2 modules	QC-1	Non-SIC	VQC-1B	6	9	4	3	22
FE Connector Assembly with 3 modules	QC-1	Non-SIC	VQC-1B	3	3	0	1	7
FE Connector Assembly with 4 modules	QC-1	Non-SIC	VQC-1B	0	2	3	1	6
FE Connector Assembly with 5 modules	QC-1	Non-SIC	VQC-1B	4	8	6	2	20
FE Connector Assembly with 6 modules	QC-1	Non-SIC	VQC-1B	3	7	11	3	24
DSM Connector Assembly with 5 modules	QC-1	SR (Safety Relevant)	VQC-1B	3	13	4	2	22
DSM Connector Assembly with 11 modules	QC-1	SR	VQC-1B	5	8	8	2	23

The quantities of the standard sub-components required to assemble all these connector assemblies in Table 2 are calculated and summarized in Appendix 2. The contractor shall manufacture these standard sub-components and assemble them according to the connector assembly drawings showing the component configuration which will be provided by IO.

The assembly drawing numbers for Batch#1 (EPP#11/EPP#12) are listed in Table 5 of Appendix 2. The drawings provided during the tendering process are only for the cost evaluation. IO will provide the approved drawings to be used for the manufacturing at the kick-off meeting after the contract is awarded.

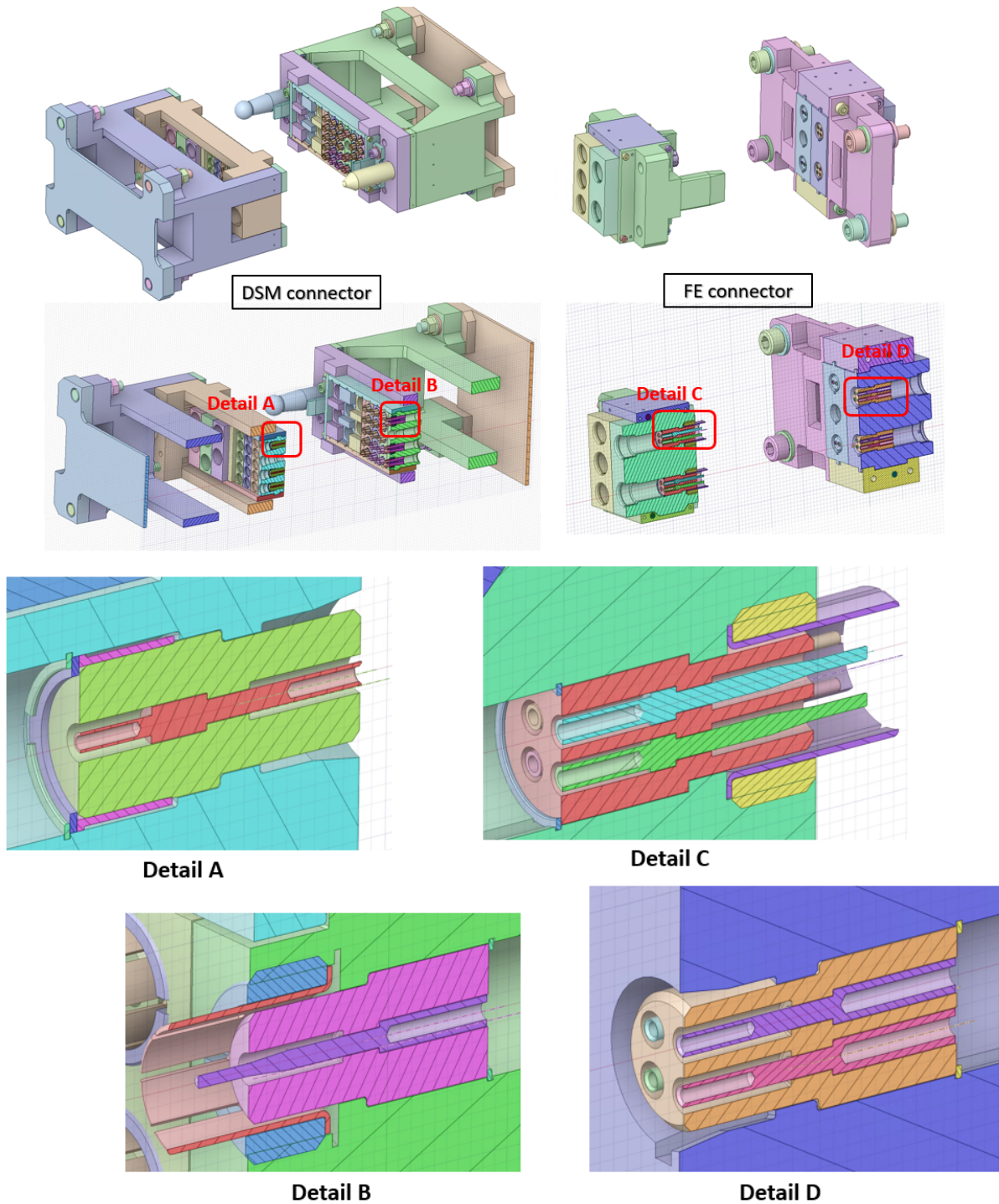

Figure 2 Design of FE connector assembly and DSM connector assembly

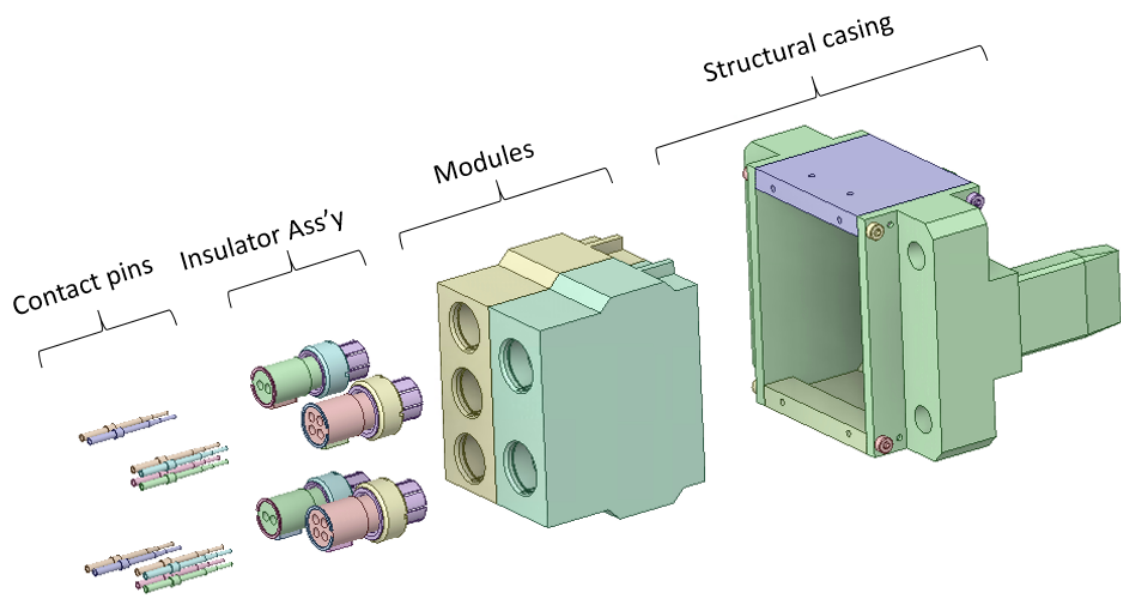

Figure 3 Sub-assemblies which FE male connector assembly is composed of

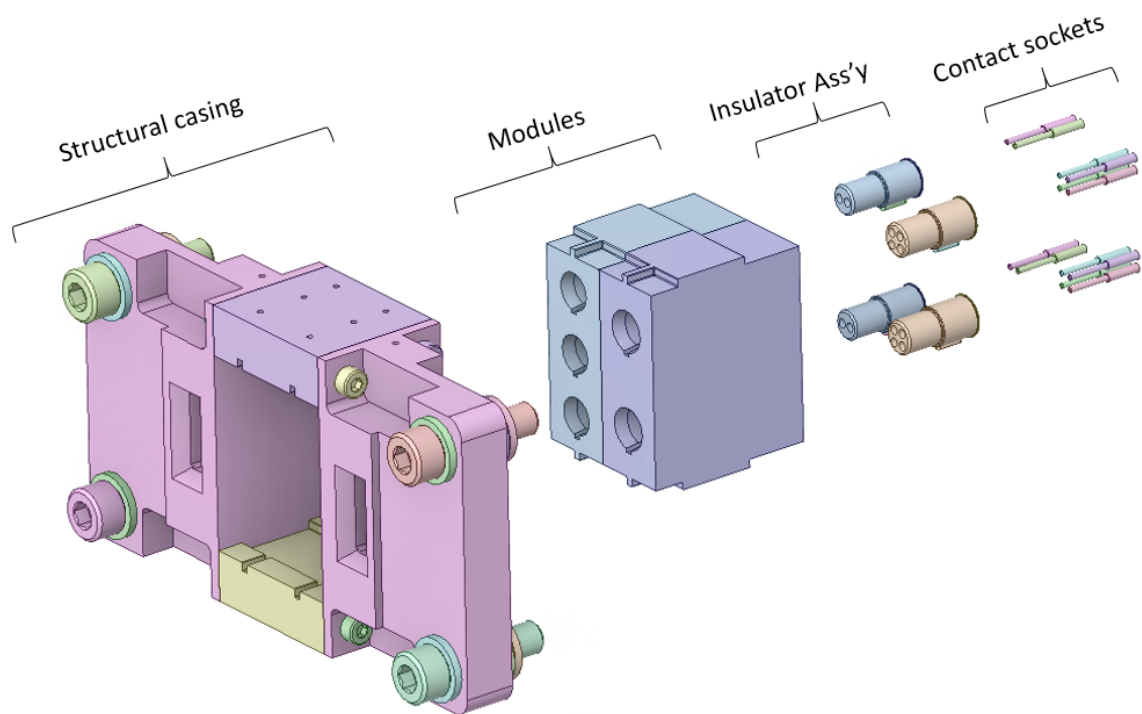

Figure 4 Sub-assemblies which FE female connector assembly is composed of

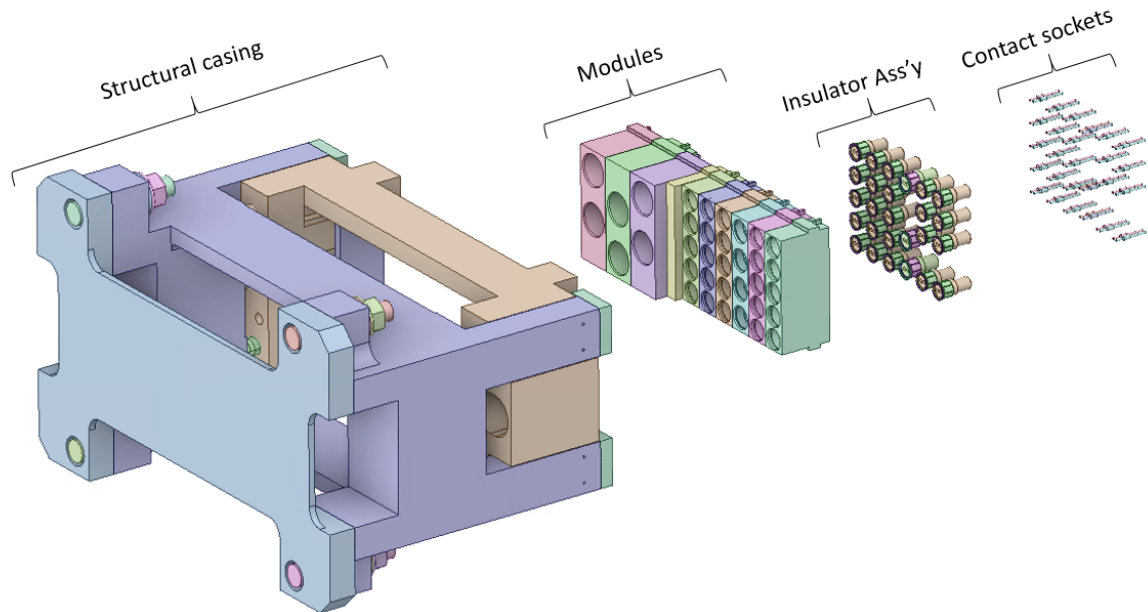

Figure 5 Sub-assemblies which DSM female connector assembly is composed of

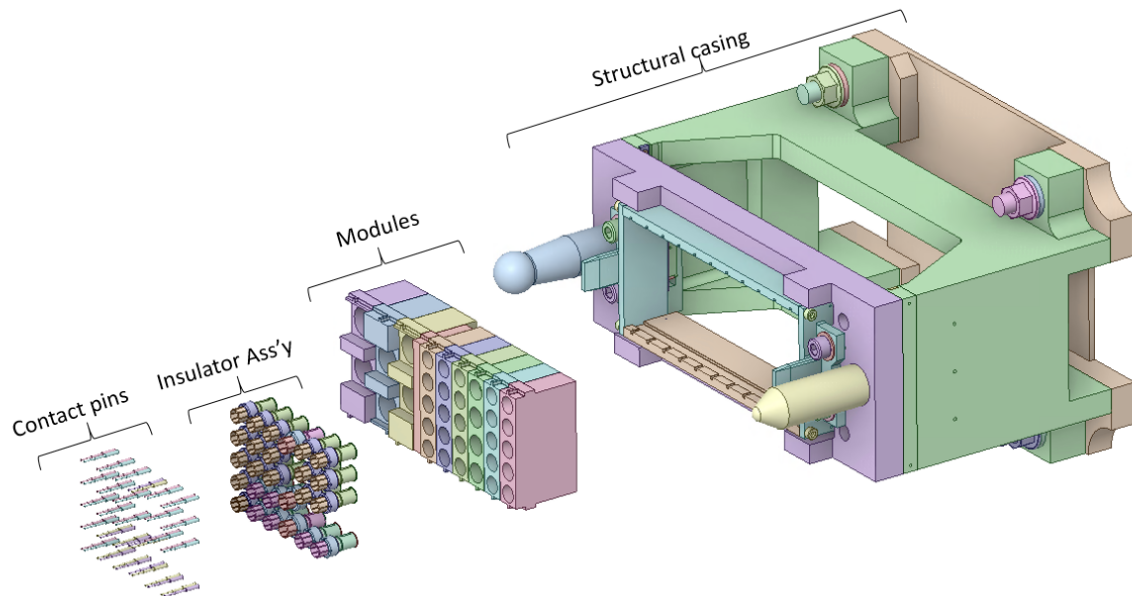

Figure 6 Sub-assemblies which DSM male connector assembly is composed of

2.2 Components not included in the scope of work

The following items are not the scope of this contract:

- Contact pin and sockets, which will be provided by IO as free-issued items.
- Raw material required to manufacture the components made of stainless steel (SS316L(N)-IG), which will be provided by IO as free-issued items.
 - IO will not provide the raw material other than Stainless Steel.
 - IO will not provide the raw material for COTS components like bolts, washers, nuts, retainer ring, keys, etc.
- MI cables and Kapton cables are not the scope of this contract. If they are necessary for testing, IO will provide them.

ITER_D_9SFDTC

2.3 Manufacturing of the components

The contractor shall prepare the Manufacturing & Inspection Plan (MIP), which is the checklist of the manufacturing procedure. The work instruction for producing the manufacturing and inspection plan is given in [RD1].

Before starting the final production, the contractor shall organize a MRR (Manufacturing Readiness Review) according to [RD2].

2.4 Factory Acceptance Test

The contractor shall perform factory acceptance test for all the products according to Section 5.2 before delivery to IO site.

2.5 Packing and Delivery

The contractor shall pack all the products, including the sub-parts and the spares and deliver to the IO site according to Section 4.

2.6 Supply of Documentation

The contractor shall provide IO with the documents and data defined in the Appendix 2 of this Technical Specification (List of Deliverables).

3 Technical Requirements

This section specifies the technical requirements which the contractor shall satisfy for the whole scope of this contract.

3.1 Description

The LEVI (Loom Electrical Vacuum Interfaces) is the electrical system which provides the electrical signal and power to the in-vessel components of the diagnostic port plug (PP). It consists of several electrical components and mechanical parts:

- LEF (LEVI Electrical Feedthrough) which transmits the electric signal and power across the vacuum boundary and the safety confinement barrier
- Diagnostics Shield Module (DSM) connector which provides the blind-mated electrical connection between the DSM and the PP closure plate
- Front-End (FE) connector which provides the blind-mated electrical connection between the DSM and the diagnostic component installed in the DSM.
- Cables: due to the harsh environment (Ultra-High Vacuum, high temperature, high neutron/gamma fluence, strong magnetic field), MI (Mineral Insulated) cables are used except for some Kapton Cables on the PP closure plate.

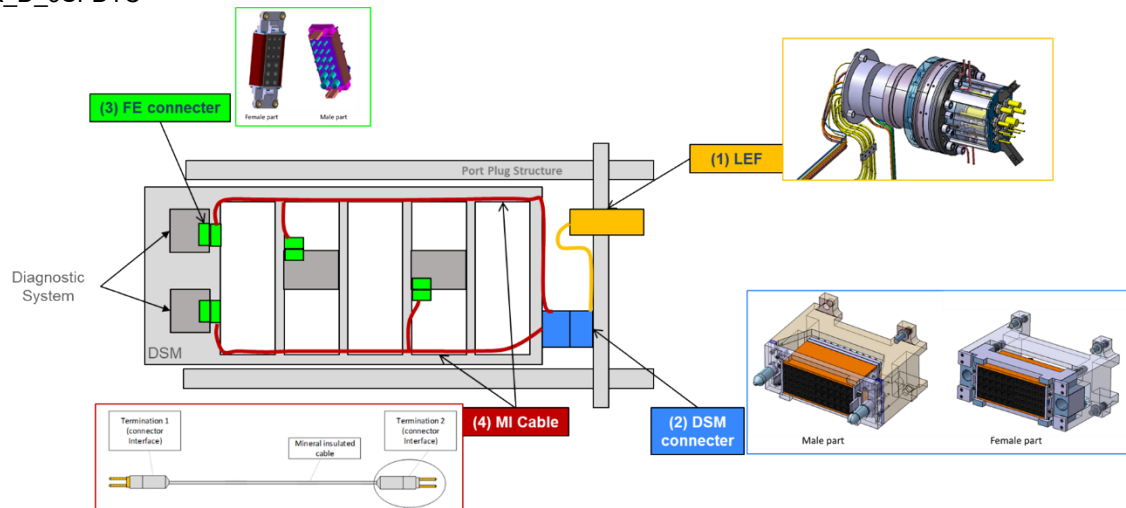

Figure 7 LEVI layout in the diagnostic port plug

The scope of this contract is the DSM connector and FE connector. These connectors are required to be compatible with the RH removal and reinstallation of the DSM assembly and the diagnostic system inside the DSM, respectively, i.e. they should be compatible with blind mating for RH maintenance.

3.1.1 DSM connector Assembly

The DSM connector realises the electrical interface between cables routed on the closure plate of the port plug structure and MI (Mineral Insulated) cables routed in the DSM structure. The male DSM connector is attached to the DSM structure and the female DSM connector is attached to the closure plate.

When the DSM structure is extracted and re-inserted from/to the port plug structure, the DSM connector provides the blind-mated connection of the cables. On top of that, they are designed to accommodate the misalignment between the DSM structure and the port plug structure during the insertion phase.

The main parts of the DSM connector assembly are illustrated in Figure 8 and Figure 9. The female DSM connector is mounted on the closure plate of the port plug structure to connect the cables coming from the LEF. The cables include both MI cables and Kapton insulated cables, depending on the signal type. The male DSM connector is mounted to the DSM structure to connect the MI cables coming from the tenant systems installed within the DSM structure.

The distance between the support base where the male and female DSM connector is fixed, i.e., between the PP closure plate and the DSM, is longer in equatorial port plug (EPP) than in the upper port plug (UPP). For that reason, it is mandatory to use a metallic shim for integration in EPP. The shim exists for both variant (11 and 5 modules) of the DSM connector.

ITER_D_9SFDTC

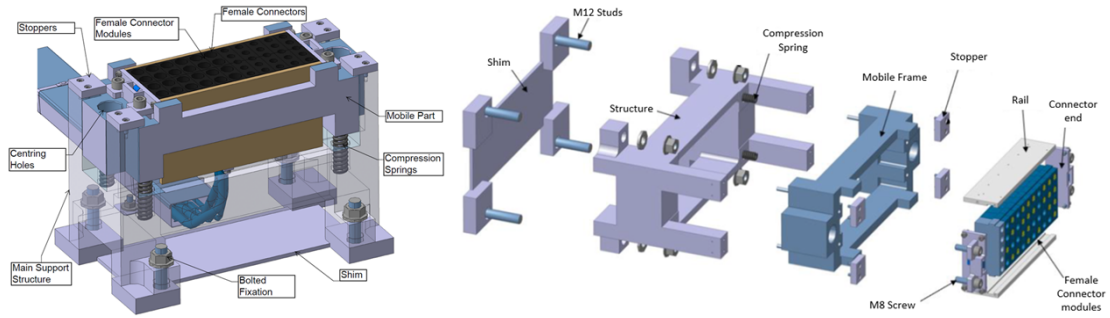

Figure 8 Female DSM connector

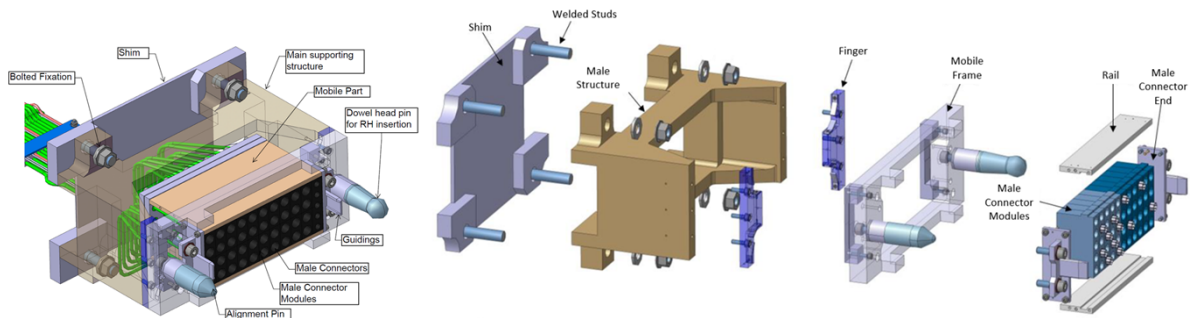

Figure 9 Male DSM connector

The DSM connector assembly has two size variations: the small one accommodates 5 modules, while the big one accommodates 11 modules. For your information, the number of modules to be accommodated is decided based on the module B1, B2 and B8 in Figure 15. Therefore, if the other bigger modules (B5, B7) are installed together, the total number of modules which can be accommodated in the DSM connector will be reduced.

The compliance mechanism in “y” and “z” direction is implemented on the male DSM connector. When the dowel and the pin are inserted into the female DSM connector, the mobile frame of the male DSM connector is guided by the fingers. Soft lamellas are welded to the finger to maintain the mobile frame during DSM connector manipulation.

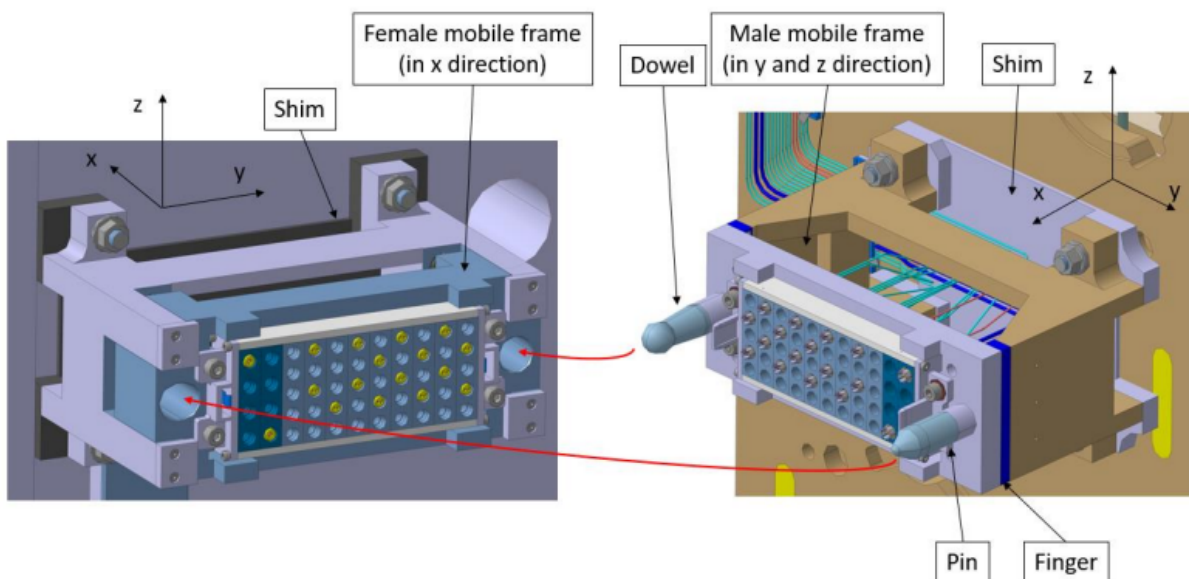

Figure 10 Misalignment compliance in Toroidal (y) and vertical direction (z) of the DSM connector during engagement

A gap between the fingers and U part ensures the compliance. The gap is at least 6mm. It consists of the sum of the following factors:

- Misalignment of $\pm 4\text{mm}$ of the DSM structure with respect to the closure plate during DSM insertion
- Positional tolerance of the male DSM connector with respect to the DSM structure $\pm 0.5\text{ mm}$.
- Positional tolerance of the female DSM connector with respect to the closure plate $\pm 0.5\text{ mm}$.
- 1mm displacement of MI cables after bending. Stiff cables can move the mobile parts of the DSM connector by 1mm, only on the male connector.

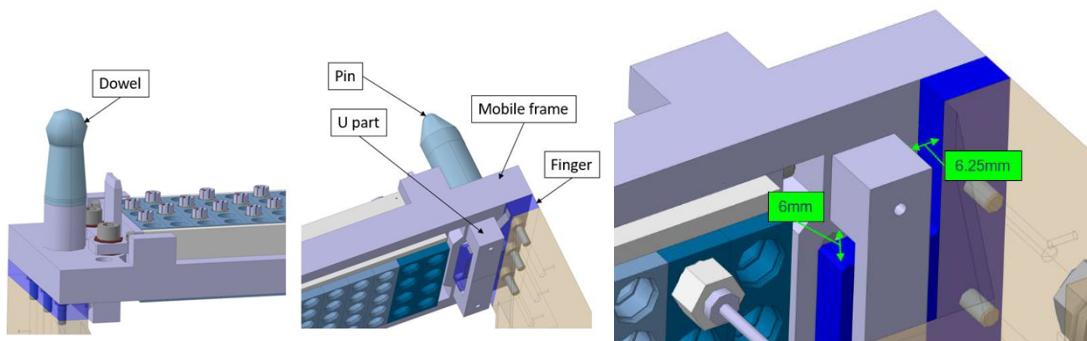

Figure 11 Compliance mechanism on the male DSM connector

The DSM connector reduces this misalignment up to $\pm 0.2\text{mm}$ between each contact pins (male and female) of the connector. The reduction is done in two steps:

- Misalignment reduction from $\pm 6\text{mm}$ to $\pm 1\text{mm}$: Function ensured by the dowel and pin assembled to the mobile frame.
- Misalignment reduction from $\pm 1\text{mm}$ to $\pm 0.2\text{mm}$: Function ensured by the guiding features of the electrical connector.

The compliance mechanism in radial direction (x) is present on the female DSM connector. During DSM insertion, stoppers on the male DSM connector are pushed against the stoppers of the female mobile frame. Behind the female mobile frame, four compression springs provide the compliance. These preloaded springs will also ensure the electrical coupling of the connector. These springs are COTS components.

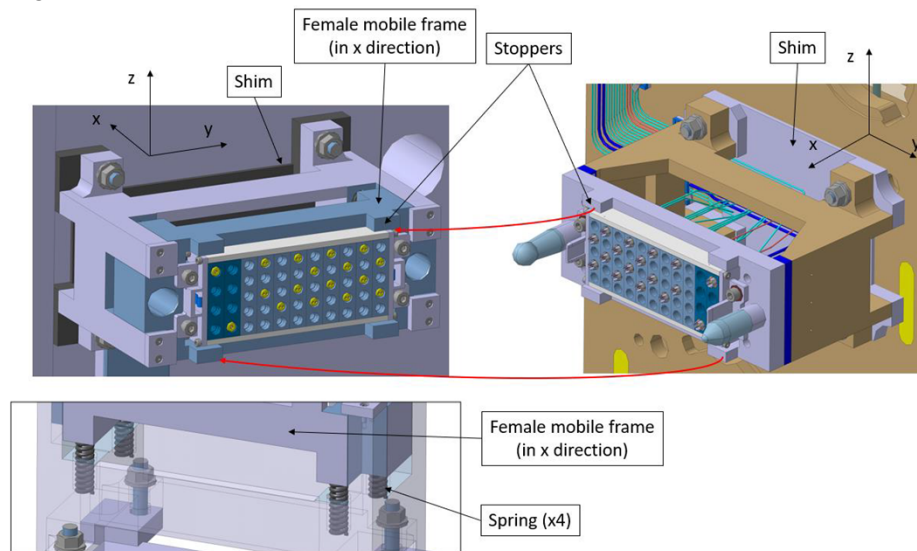

Figure 12 Compliance mechanism in radial (x) direction of the DSM connector

The female mobile frame is made of Aluminium-Nickel Bronze (UNS C63200 in accordance with ASTM and CuAl10Ni5Fe4 in accordance with EN standards) [RD17], in order to have better tribological properties and to avoid any risks of seizing or jamming during displacement.

3.1.2 FE Connector Assembly

The FE connector provides the MI cable connection for the tenant diagnostic components installed in the DSM structure. The MI cables routed on the DSM structure go to the diagnostic components through the FE connectors. The FE connector is compliant with blind-mated connection for the RH maintenance of the diagnostic components.

The design of the FE connectors is very similar to the design of the DSM connector, except for the big structural part to provide structural strength and misalignment compliance mechanism for the DSM insertion.

The FE connector has 6 size variations depending on the number of modules accommodated, just like the DSM connector. For each size variation, there is a standard structuring casing. See Figure 14. The smallest one can host only one module, while the biggest one can host 6 modules.

The female FE connectors are directly mounted on the DSM structure and it provides the compliance mechanism for a small range of misalignment (± 1 mm in all directions). On the other hand, the male FE connector is rigidly fixed to the tenant diagnostic component.

The rectangular guiding pins located on the male FE connector is used for the alignment of the female part of the FE connector. The female part of the connector interfaces with the DSM structure by means of a loosen attachment, allowing to compensate misalignment of ± 1 mm along three axis. This loosen attachment is four shouldered rings fixed to the DSM structure by means of M8 bolt. The gap between the casing and the ring allow ± 1 mm of compliance in the toroidal and vertical direction. In the radial direction, a spring washer pushes the female FE connector against the male connector and absorb 1mm extra stroke.

ITER_D_9SFDTC

3.1.3 Structural casing

As mentioned before, the DSM connector has 2 size variations and the FE connector has 6 size variations. The structural casing design is identical for these size variation, except for the length variation required to accommodate the number of modules. Figure 13 shows the DSM connector structural casing design for two size variations and Figure 14 shows the FE connector structural casing design for six size variations.

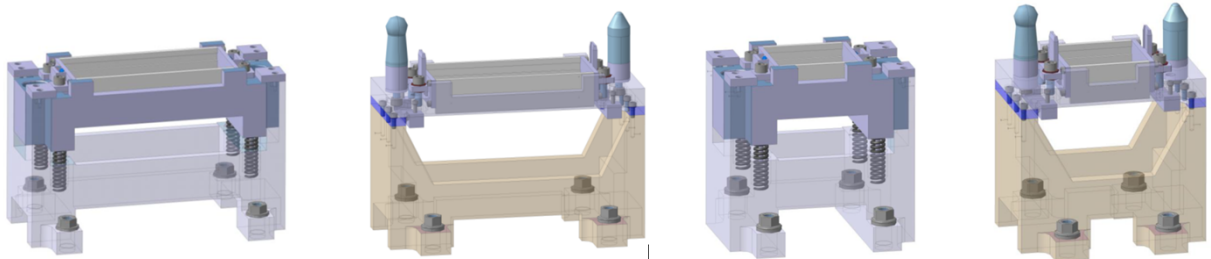

Figure 13 Structural casing of the DSM connector: the large one with 11 modules (on the left) and the small one with 5 modules (on the right)

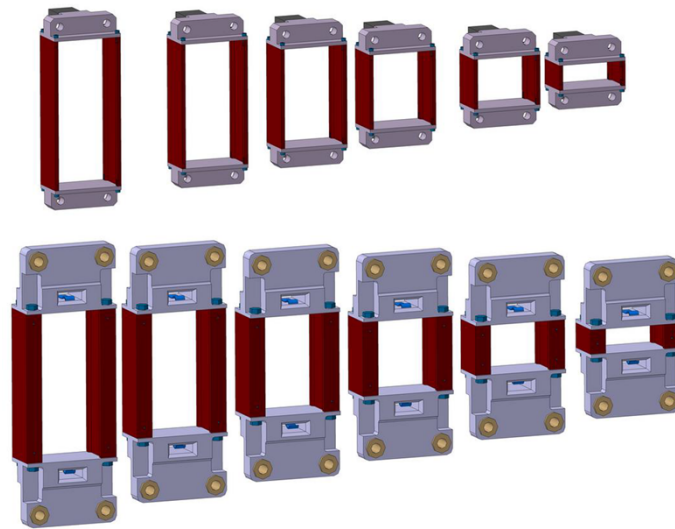

Figure 14 Standard structural casing of the FE connector (top: male casing, bottom: female casing)

3.1.4 Connector Modules

The modules are the mechanical interfaces between the insulator assembly and the structural casing. There are 5 types of standardized modules for the DSM connector and 8 types of standardized modules for the FE connector. Figure 15 and Figure 16 shows their design.

ITER_D_9SFDTC

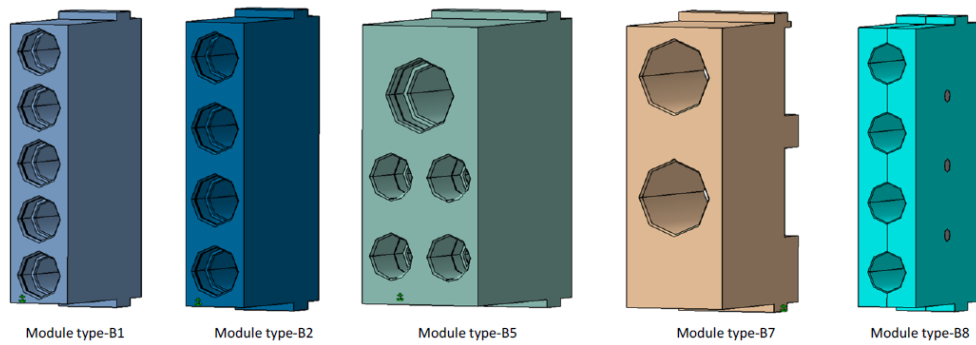

Figure 15 Standard modules for the DSM connector

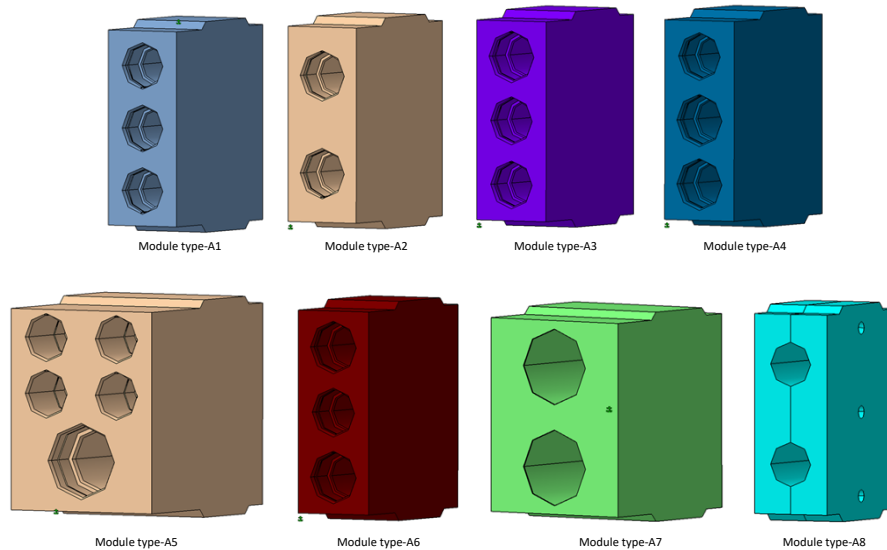

Figure 16 Standard modules for the FE connector

The insulator assemblies are installed to these modules, as shown in the detail view of Figure 2. They are fixed with a retainer ring (Detail view A, B, D in Figure 2). The ones used for the male connector are fixed with a retainer ring and a nut (Detail view C in Figure 2). The type of the insulator assembly, i.e. the MI cable type which each module can accommodate, is defined and summarized in Appendix 3.

Unlike most of the modules which accommodate the insulator assemblies for MIC1 ~ 8 and MIC11, the modules A7/B7 and A8/B8 do not get the insulator assembly installed, but they accommodate a RF connector which is welded to the end of a coaxial (MIC9) or triaxial (MIC10) MI cable. In other words, these modules will simply clamp the RF connector mechanically. See Figure 17.

A shoulder of the coaxial termination (RF connector) stops the displacement along + x direction and a retaining ring stops the displacement along -x direction. There is radial gap of 0.1mm between the cable termination and the module in order to have a compliance during mating.

For Triaxial MI cable, a shoulder on the triaxial termination (RF connector) is captive in the module A8/B8 assembly. There is also a radial gap of 0.1mm between the cable termination and the module in order to have a compliance during mating. Especially, its inner surface of this module which has contact with Triaxial termination shall be coated with ceramic (Alumina) for electrical insulation.

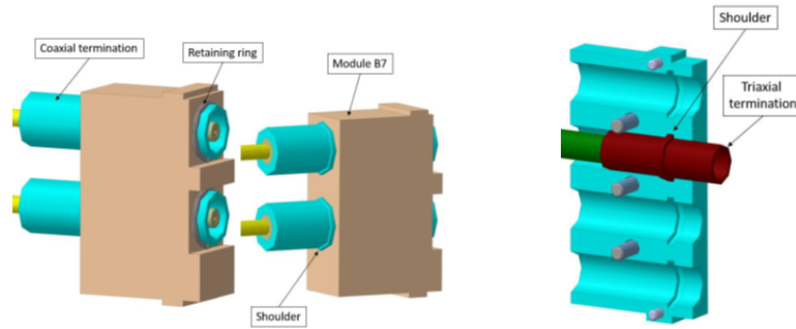

Figure 17 Module A7/B7 and A8/B8 for coaxial MI cable and triaxial MI cable.

The module also provides the mechanical interfaces to fix the MI cable or the Kapton cable. Even though the MI cable and the Kapton cable is not the scope of this contract, the design concept for the cable fixation is explained here for information. The MI cable is fixed with a retainer ring as shown in Figure 18. The Kapton cable wire is directly crimped with the crimping barrel of the contact pin of the insulator assembly and a metal part (called as “nut” in Figure 19) will support and protect the Kapton cable.

It should be noted that the retainer ring and the metal part (nut) are the part of the module and so they are the scope of this contract.

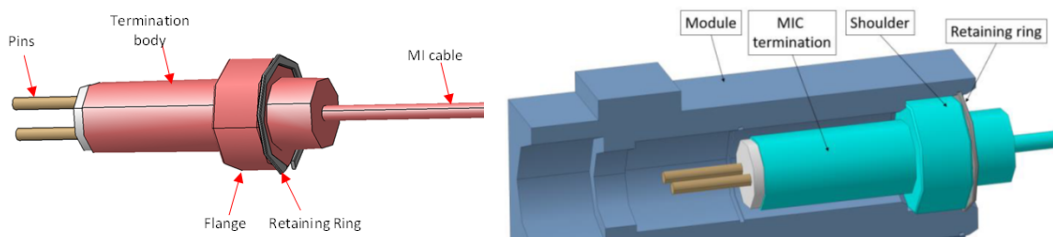

Figure 18 Module interface with MI cable (MI cable termination on the left)

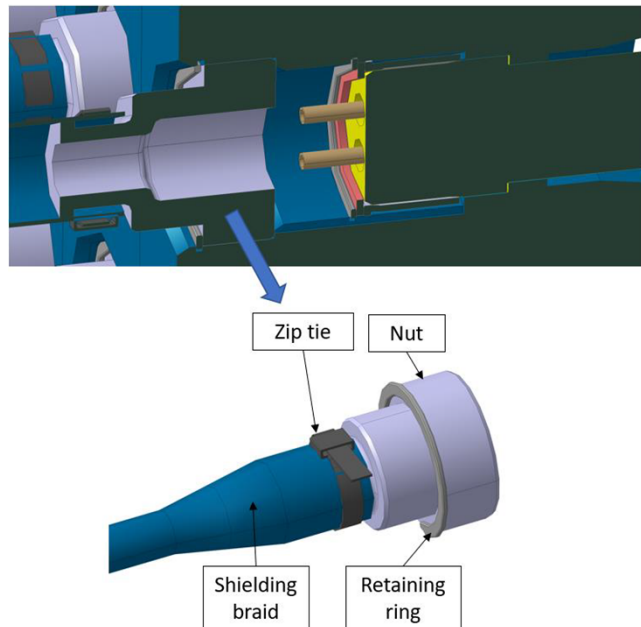

Figure 19 Interface between Kapton cable and module

3.1.5 Insulator Assemblies

There are three versions in the insulator assembly

- Insulator Assembly-Male for male FE connector and male DSM connector
- Insulator Assembly-Female for female FE connector
- Insulator Assembly-Female Crimped for female DSM connector

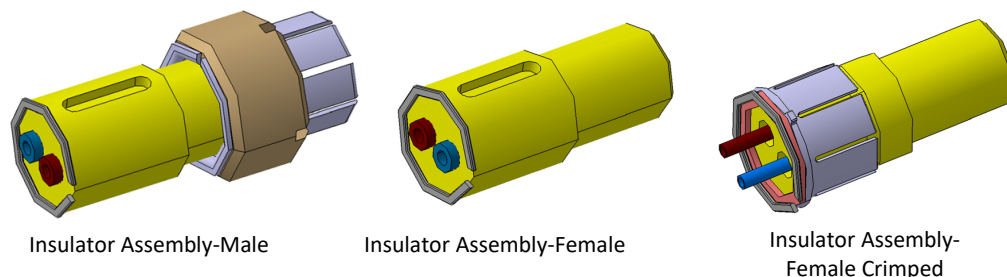

Figure 20 Types of insulator assembly

The main body is made of ceramic (Alumina, Al_2O_3) and it provides the electrical insulation between conductor (contact pin & socket) and the surrounding structural body.

The male insulator is designed for both the male DSM connector and the male FE connector. As shown in Figure 21, it has the male contact pin inside the ceramic. There is a shielding protection part which is fixed to the module with a nut. It will provide EM shielding for the connection part between the contact pin on the male connector side and the contact socket on the female connector side. The key hole made in the ceramic will be used only for the FE connector to ensure that the connector is positioned in the module with right angular orientation. For the DSM connector, the angular alignment of the contact pins is not required and so there will be no key in the module.

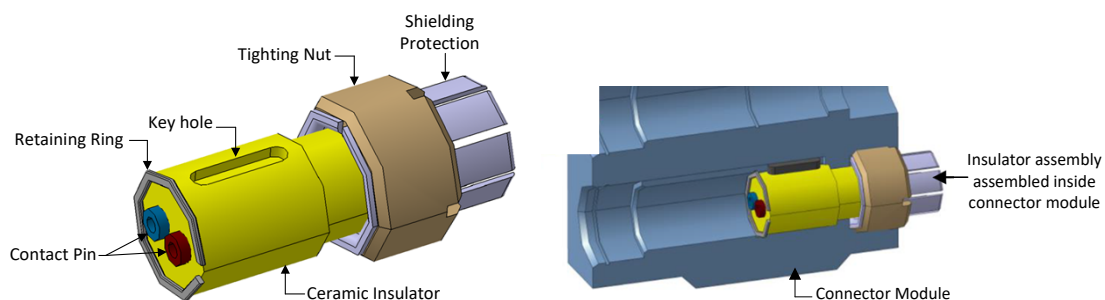

Figure 21 Male insulator assembly

The female insulator assembly is installed on the female part of the FE connector assembly. It has the contact socket inside the ceramic which will match the contact pin of the counterpart male connector. The ceramic insulator is fixed to the module with a retainer ring, like the male insulator assembly. And the key on the insulator body ensures the right angular orientation of the contact sockets.

ITER_D_9SFDTC

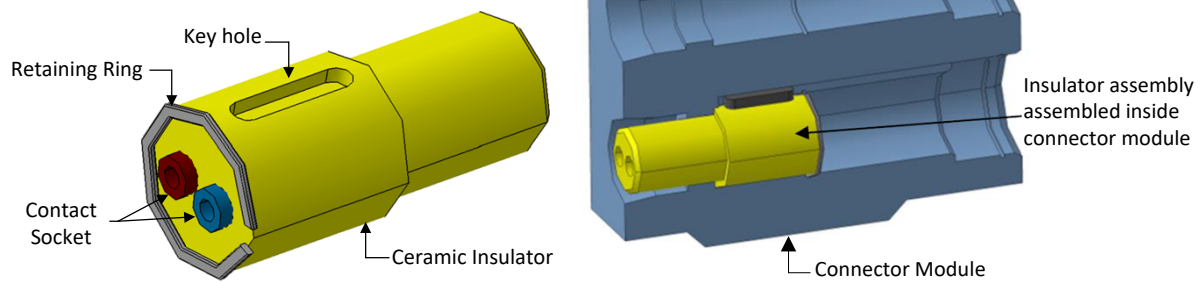

Figure 22 Female insulator assembly for the female FE connector

The female crimped insulator assembly is installed on the female DSM connector which provides the connection with Kapton cables. For this interface with Kapton cables, a crimping version of the contact socket is installed inside the ceramic. This version of insulator does not have a key hole. Instead, a collet is used to prevent the ceramic insulator rotation by friction. In this way, this insulator can be rotated freely during initial assembly in order to align the contact sockets with the contact pins of the counterpart male DSM connector.

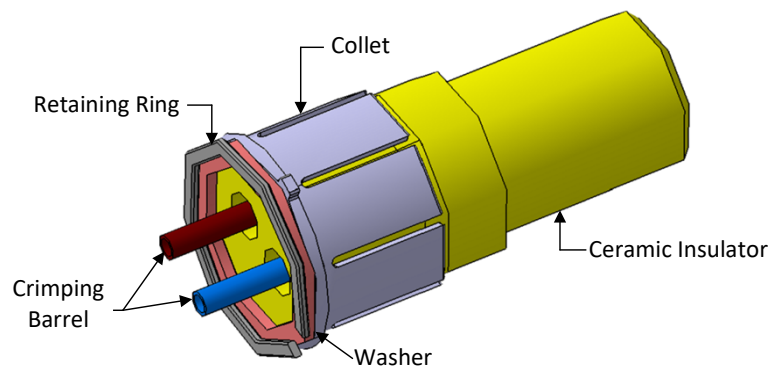

Figure 23 Female crimped insulator assembly

3.2 Manufacturing Design Requirements

[RQ-1] The contractor shall prepare the manufacturing models and drawings implementing the manufacturing approach to satisfy the requirements (tolerances, surface condition, etc) specified in 2D drawings provided by IO as well as the technical requirements specified in this document. The final manufacturing models and drawings shall be checked and approved/accepted by IO before starting the manufacturing.

[RQ-2] The contractor shall prepare all manufacturing procedures based on the final manufacturing drawings which will be reviewed in a Manufacturing Readiness Review (MRR) prior to the manufacturing start

3.3 Material Requirements

ITER_D_9SFDTC

- [RQ-3] The materials of each part shall be consistent with the ones specified in the 2D drawings provided by IO.
- [RQ-4] The material properties shall be compliant with the ITER material handbook [RD3].
- [RQ-5] The metallic parts shall satisfy the impurity content limitation to reduce material activation and radwaste: Co < 0.05%, Ta <0.01%, Nb <0.01%. If this impurity content limit cannot be satisfied due to procurement difficulties in the market (e.g., small COTS parts like bolts, washers, etc), the contractor shall submit a Deviation Request and get IO approval before procurement.
- [RQ-6] Materials shall have a relative magnetic permeability ≤ 1.03 . As the machining operation may change the magnetic property, the magnetic permeability shall be measured after machining to confirm that it is still less 1.03.
- [RQ-7] Materials shall be free of Halogenated materials.
- [RQ-8] The ceramic insulator shall be machinable Alumina (>96%, ASME D2442 type III or IV). As alternative, Shapal-M or equivalent aluminium nitride product can be used under IO approval.
- [RQ-9] Only materials accepted for the relevant Vacuum Classification shall be used. All material for use in vacuum shall be clearly specified and certified in accordance with EN 10204 3.1 or 3.2 before being used in manufacturing. (Ref. Section 5.1 in IVH [AD1]) The list of materials accepted for ITER is listed in [RD4]. For the materials which are subject to restricted use or not on the accepted list, the contractor can submit Material Acceptance Request and they can be used only with IO's approval. (Ref. Section 5.2 in IVH [AD1])
- [RQ-10] The outgassing rates of materials shall be consistent with the values in Table 5.1 in IVH [AD1].
- [RQ-11] Halogenated materials, sulphur and phosphorus, and processes involving the use of these materials, shall be avoided. These materials lead to potential for oxidation catalyst poisoning and to metallic corrosion due to acid formation.
- [RQ-12] Certification in accordance with EN 10204 shall be provided. Other materials, or materials without the EN 10204 certification, shall be supplied with a supplier's certificate of conformity.
- [RQ-13] The determination of material properties and functional attributes of the insulation material (ceramic) shall be determined by standardised methods. Where no standard method exists, the procurement of the insulation material shall be carried out according to technical specifications which are prepared by the contractor and accepted by IO. The technical specifications of material shall specify the testing methods and the related acceptance criteria.

3.4 Codes and Standards

- [RQ-14] In general sense manufacturing methods and procedures shall follow the reference code RCC-MR 2007 for class 2 box structures in consistency with the document "Codes and Standards for ITER Mechanical Components" [RD9].
- [RQ-15] It should be noted that there are no European or International Standards with respect to proper fabrication of ultra-high vacuum (UHV) components and so in lieu of an industrial Standard the DSM connectors and FE connectors fabrication shall simultaneously comply with the "ITER Vacuum Handbook" [AD1].

ITER_D_9SFDTC

[RQ-16] Other equivalent national or international Standards and Codes proposed by the contractor may be acceptable with prior written IO approval, provided conformity assessment to all criteria is satisfied.

3.5 System classifications

This section outlines the different DSM connector and FE connector classifications regarding safety, quality, vacuum and PED/ESPN as their consideration is closely related to the requirements defined in this Technical Specification.

3.5.1 Safety classification

[RQ-17] The contractor shall consider DSM connectors SR and FE connectors as Non Safety Important (Non-SIC) Components as defined in [RD10] in their manufacturing procedures as well as in the application of the requirements included in the Technical and Management Specifications.

3.5.2 Quality Assurance Classification

Attending to the functional risk and the economic impact of their failure on the ITER machine performance and availability, DSM connectors and FE connectors are classified as QC-1.

[RQ-18] The contractor shall consider DSM connectors and FE connectors as QC-1 components as defined in [RD12] in their manufacturing procedures as well as in the application of the requirements included in the Technical and Management Specifications

3.5.3 Vacuum classification

[RQ-19] The contractor shall consider DSM connectors and FE connectors as VQC-1B components as defined in [AD1] in their manufacturing procedures as well as in the application of the requirements included in this Technical Specification

3.5.4 Classification according to PE/NPE French regulations

The RH connectors are not a pressure equipment.

3.6 CAD activities and engineering drawings

CAD activities within the scope of the contract are managed through the System for the Management of Diagrams and Drawings (SMDD) which is the single common IO repository for all Diagrams and Drawings in pdf format.

[RQ-20] CAD related activities within the scope covered by this Technical Specification shall follow the requirements in [AD7].

ITER_D_9SFDTC

3.7 Manufacturing requirements

This section defines the requirements on manufacturing. Detailed Quality Plans, Manufacturing Inspection Plans (MIP), work plans and manufacturing procedures shall be developed by the contractor for each step of manufacturing as defined in [RD1] and [AD3]. They shall be submitted to IO for review and approval/acceptance before starting manufacturing.

The contractor shall use the IO MDB (Manufacturing DataBase) system [RD15] to manage the manufacturing process as per the approved MIP.

The overall manufacturing sequence is first to fabricate all the sub-parts listed in Appendix 1 required for all the batches, including spares. Then the assembly of each connector listed in Table 2 is made using these sub-parts already manufactured according to the assembly drawing of each connector. As shown in Figure 1, the fabrication of the sub-parts should be planned to comply with the delivery schedule of each batch.

3.7.1 Machining and assembly requirement

Machining operations are required in order to achieve the final dimensional requirements of the DSM connector and FE connector components.

Nominal dimensions of all parts coming from previous manufacturing stages will present extra thicknesses and/or extra length in order to allow a final machining of the whole assembly so that final dimensions are reached through removal of the extra material. This additional material coming from part dimensions before final machining has to be controlled at design and also at assembly stage in order to ensure that it will be placed where needed for subsequent operations or stages.

[RQ-21] Machining operations shall guarantee the functional tolerances and surface finish conditions stated in drawings in order to ensure a correct service of the component, particularly:

- Compliance with blind-mating of male and female connector compatible with remote handling maintenance
- Compliance with assembly requirements
- Compliance with the structural dimensions

[RQ-22] Care shall be taken in manufacturing processes so as not to introduce contaminants into surfaces which may be difficult to remove later and which might result in degraded vacuum performance.

[RQ-23] The design and set-up of machining processes shall be optimized so that the magnetization of austenitic stainless steel parts is below the limits specified in [RQ-6].

[RQ-24] The fasteners shall be tightened as per the torques specified in the assembly drawings.

[RQ-25] The assembly shall be made using power free latex or nitrile gloves (over cotton or linen if desirable) after the sub-parts are cleaned and completed dried.

[RQ-26] Intensive care should be taken of using the correct sub-parts for the assembly as per the assembly drawing and a checklist shall be made to ensure the assembly compliance to the drawing.

[RQ-27] The number of engagement and disengagement cycles of the contact pin and socket shall be restrained less than 5 times during the whole manufacturing process, including all the tests (reception test, FAT, etc) to prevent the damage of the soft gold plating.

ITER_D_9SFDTC

Austenitic stainless steels when cold worked may increase locally their magnetic permeability. The change occurs because the cold work deformation induces a transformation of the microstructure from austenite to martensite. Within the surface layer of a stainless steel the growth of martensite is induced by the cold deformation during a machining process. This increases the magnetic relative permeability of the steel. Among other ways, like removing the layer or optimizing the machining parameters and tools, the magnetization of austenitic stainless steels may be controlled.

3.7.2 Vacuum and Cleanliness requirement

- [RQ-28] The cutting and machining fluid shall be selected as per Section 6.1 in IVH [AD1]. The use of other cutting fluids shall require prior acceptance by IO. They shall be water soluble, non-halogenated and phosphorus and sulphur free.
- [RQ-29] Components for different VQC shall be supplied with the maximum average surface roughness listed in Table 8-1 in IVH [AD1]. (Ref. Section 8.1 in IVH [AD1])
- [RQ-30] Parts and sub-components shall be degreased using solvents or alkaline detergents, rinsed with demineralised water, and dried in hot gas or an oven to accepted procedures. The use of halogenated solvents is forbidden at any stage. Lists of accepted cleaning fluids can be found in [RD5]. (Ref. Section 6.2 in IVH [AD1])
- [RQ-31] All components shall be subjected to a rigorous cleaning procedure, consistent with the Vacuum Classification of that particular component. A guide to cleaning and handling of components for use on ITER vacuum systems can be found in [RD6]. A detailed Clean Work Plan shall be submitted for prior acceptance to the ITER Vacuum RO before any cleaning operations are undertaken at the contractor's site. (Ref. Section 24.1 in IVH [AD1])
- [RQ-32] Abrasive techniques to clean or to attempt to improve the appearance of the surfaces of vacuum components must be kept to an absolute minimum and are preferably avoided. (Ref. Section 24.3 in IVH [AD1])
- [RQ-33] Pickling and passivation must always be followed immediately by an appropriate cleaning process relevant to the VQC of the component. A guide to the pickling/passivation of steels and copper can be found in [RD7]. (Ref. Section 24.4 in IVH [AD1])
- [RQ-34] After final cleaning, the handling of vacuum equipment shall be strictly controlled to preserve cleanliness as per Section 24.5 in IVH [AD1]. The mandatory requirements relating to cleanliness during assembly of vacuum equipment are detailed in [RD8].
- [RQ-35] Surfaces which are to be exposed to vacuum shall only be marked or identified if necessary and shall be marked by scribing with a clean sharp point, laser scribing or electromagnetic dot peen method. (Ref. Section 28 in IVH [AD1])

3.7.3 Metrology and tolerances

- [RQ-36] During the different stages of the manufacturing several dimensional controls shall be required. Such inspections could be carried out by traditional linear measuring systems (e.g. meter, caliber, micrometer, thickness gauge) or by 3D dimensional inspection equipment (e.g. CMM, laser tracker, laser scanner, photogrammetric).
- [RQ-37] Additionally, a final factory acceptance dimensional inspection shall be carried out after completion of DSM connectors and FE connectors.

3.7.4 Copper coating requirements

- [RQ-38] Only for all the male FE connectors, the structural casings and the modules shall be coated with copper to reduce the absorption of EM radiation in the millimeter wave range.
- [RQ-39] The purity of the deposited copper shall be > 99%.
- [RQ-40] The contractor shall determine if an interlayer is required (e.g. nickel) in order to achieve satisfactory performance of the copper coating.
- [RQ-41] The thickness of the copper coating shall be 5 μm +/- 20%.
- [RQ-42] For the anodes to be used in the coating process, Oxygen Free Copper material shall be selected.
- [RQ-43] The surface roughness of the coating shall not exceed $R_a = 1.6$ microns.
- [RQ-44] To qualify the copper coating technique, the contractor shall carry out the following tests for 10 samples (100mm x 20mm x 5mm) made of SS316L(N).
- Coating shall successfully pass 10 thermal cycles (room temperature to 350°C) (pass criteria: no flaking, blistering or spalling of the coating).
 - The coated samples shall pass outgassing tests (pass criteria: Table 5.1 in IVH [AD1])
 - The coated samples shall pass the adhesion test according to ISO 2819 standard.

3.7.5 Ceramic coating requirements

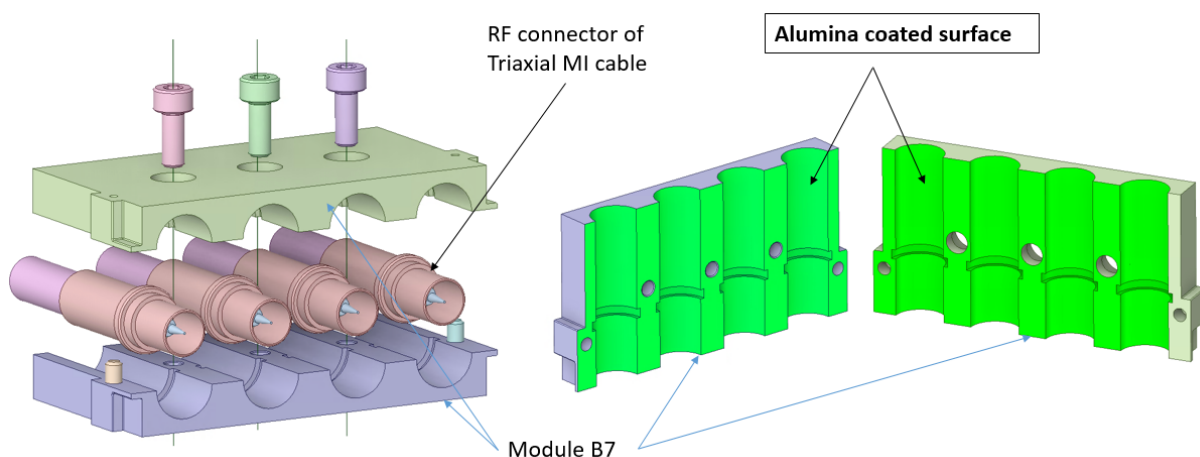

Figure 24 Module B7 for the triaxial MI cable and the surface to be coated with Alumina for electrical insulation between the RF connector of Triaxial MI cable and the Module (highlighted in green color)

- [RQ-45] The pair of modules A7 & B7 for the triaxial MI cable shall be coated with Alumina (Al_2O_3) to insulate electrically the RF connector of the triaxial MI cable from the module grounded to the machine. The surface of the module B7 to be coated is indicated in Figure 24. This coating shall be applied to the module A7 in the same way.
- [RQ-46] The shielding protection installed in the male insulator assembly in Figure 21 shall be coated with Alumina to mitigate the voltage breakdown of the core conductor.
- [RQ-47] The Alumina coating thickness shall be 10 ~ 25 μm .
- [RQ-48] The surface roughness of the coating shall not exceed $R_a = 6.3$ microns.
- [RQ-49] There are coating techniques (plasma spray, thermal spray and chemical vapour deposition) which are well-developed and commercially established for almost all ceramic

ITER_D_9SFDTC

materials. The contractor shall propose a suitable coating technique and carry out the following tests for 10 samples of a simplified A7 module to qualify the coating quality:

- Coating shall successfully pass 10 thermal cycles (room temperature to 350°C) (pass criteria: no flaking, blistering or spalling of the coating).
- The coated samples shall pass outgassing tests (pass criteria: Table 5.1 in IVH [AD1])
- The coated samples shall pass the adhesion test according to ISO 23114 standard.

3.8 CE Markings

CE Markings shall be implemented in accordance with European directives requirements. The list of European directives concerning CE marking is available on the following web site <http://www.conformance.co.uk/directives/index.php>. Other useful information can be found in the “Guide of implementation of directives based on the New Approach and the Global Approach”: http://ec.europa.eu/enterprise/policies/single-market-goods/files/blue-guide/guidepublic_en.pdf.

4 Delivery

The contractor shall deliver to the IO site the in-series final products of the connector assembly listed in Table 2 as per the delivery schedule in Figure 1.

4.1 Requirements for labelling, cleaning, packaging, handling, shipment and storage

4.1.1 Scope of application

The following generic requirements shall apply for the shipments of the components (sub-parts or final product) from the manufacture/assembly site to the IO Site or for the shipments from the manufacture/assembly site to any intermediate site.

Suitable precautions shall be taken to avoid damage to the components. The components shall be fitted with the required accelerometers or other sensors and shall be packed as defined below.

The components shall be subject to control and inspection, as defined below.

4.1.2 Labelling and Traceability

[RQ-50] All the final products and the main sub-parts shall be clearly marked in a permanent undeletable way and in a visible place as per [RQ-35].

[RQ-51] All labelling, color coding and signage shall be standardized to reduce the likelihood of error. The IO guideline is given in [RD12].

[RQ-52] All labelling shall follow the IO official numbering system according to the document “ITER Numbering System for Components and Parts” [RD13]. A detailed ‘IO component identification standard’ together with printed label templates and RFID tagging standards will be provided by IO

4.1.3 *Preservation of cleanliness*

- [RQ-53] Requirements of cleanliness shall be achieved during the last phase of fabrication in which the verification of the applicable criteria is possible and shall be maintained until the delivery and final acceptance of the component.
- [RQ-54] Requirements in RF 6620 of RCC-MR 2007 relative to protection and preservation of cleanliness shall be respected as long as they are compatible with [AD1] (Section 24). Otherwise, requirement in later reference shall prevail.
- [RQ-55] After final cleaning, the handling of vacuum equipment shall be strictly controlled to preserve cleanliness. General area cleanliness requirements pertaining to VQC-1 components are summarized in Table 24-1 of [AD1]. These requirements shall be also observed.
- [RQ-56] For VQC-1 the continuing suitability of any given area used for handling vacuum equipment should be checked on a regular basis by monitoring the airborne particulate count, which should not exceed 5×10^6 particles of size $> 0.5 \mu\text{m}$ per m^3 .
- [RQ-57] Further fabrication, conditioning, transportation, etc., shall also include dispositions to preserve and/or reconstitute the required degree of cleanliness according to aforementioned requirements.

4.1.4 *Storage Requirements*

- [RQ-58] Requirements in RF 6630 of RCC-MR 2007 shall be applicable for components assigned to class B.
- [RQ-59] After final cleaning items have to be stored in the clean area.
- [RQ-60] For intermediate storage safe places shall be chosen, i.e. away from tracks of fork lifters and other industrial trucks. Preferably items shall be stored not on the floor to avoid, that things are falling to them and cause damage.
- [RQ-61] Items shall not be stored together with carbon steel.

4.1.5 *Packaging and Handling*

- [RQ-62] The contractor shall design and supply appropriate packaging, adequate to prevent damage during shipping lifting and handling operations.
- [RQ-63] Where appropriate, accelerometers or other sensors shall be fitted to ensure that limits have not been exceeded. When accelerometers are used, they shall be fixed onto each box.
- [RQ-64] Shock absorbing material shall be used.
- [RQ-65] Components shall be packed with adequate protection from thermal or mechanical stresses which may adversely affect the operation of the component. All packing shall be sealed and marked externally with the component VQC. Handling instructions shall also be clearly marked on the outside of the packaging. All such marking shall be in English and French. (Ref. Section 29 in IVH [AD1])
- [RQ-66] All vacuum components shall be shipped dry internally and externally, irrespective of final acceptance testing at the contractor's site. (Ref. Section 29 in IVH [AD1])
- [RQ-67] The use of adhesive tape for the protection and packaging of vacuum components shall be restricted to prevent the risk of contamination from the tape. In particular, tape used on austenitic stainless steel shall meet leachable chloride and fluoride limits of 15 ppm and 10 ppm, respectively. Where used, tape shall be fully removable leaving no

ITER_D_9SFDTC

residue, using isopropyl alcohol or acetone as the solvent to remove all traces of the adhesive. (Ref. Section 29 in IVH [AD1])

[RQ-68] To prevent damage and possible contamination during transit, the packaging of components shall be done as soon as possible after acceptance testing and final cleaning at the contractor's premises. Cleaning and packaging operations may be witnessed by ITER. (Ref. Section 29 in IVH [AD1])

[RQ-69] Where practical, vacuum components shall be entirely enclosed in heat sealed polyethylene for shipping. The polyethylene enclosure shall be purged and backfilled with dry air (<4000 ppm H₂O). Where this is not practical, alternative conditions shall be accepted by IO. (Ref. Section 29 in IVH [AD1])

[RQ-70] Prior to delivery to ITER site, the components shall be stored in clean and dry conditions, protected from normal hazards.

Each shipment shall be accompanied by a Delivery Report which shall be prepared by the contractor, stating as a minimum:

- The packing date;
- The full address of the place of delivery and the name of the person responsible to receive the package, as well as of the contractor's name and full address;
- Bill of Materials
- Security Measures
- Release Note [AD5];
- Packing List;
- Material Safety Sheet;
- The declaration of integrity of the package;
- The declaration of integrity of the components;
- Any additional relevant information on the status of the components.

The Delivery Report shall be signed by a representative of the IO and the contractor. The signature by the IO of the Delivery Report prior to shipment represents a Hold Point (HP).

The Manufacturing Dossier is part of the List of Deliverables in Appendix 2.

An example of Manufacturing Dossier is listed below:

- As-Built Drawings, Documents, and Data (with signatures)
- Contractor Release Note
- Quality Plan
- Testing Procedures, Specifications and Reports
- Material Control Reports, incl. Certificates, Inspections, Concessions etc.,
- Manufacturing Documentation, incl. Machining procedures, assembly procedures, cleaning procedures, Non-Destructive Testing (NDT) Procedures, Process specifications etc.,
- Records of approved Non-Conformances (NCR) and Deviation Requests (DR)
- Certificates of conformance

ITER_D_9SFDTC

- Control Reports (Visual Examination, Non-Destructive Tests, Certificates of Cleanliness, Geometric measurements, etc.)
- Codes and Standards conformity certificates
- Completed Manufacturing & Inspection Plans
- Manuals and Instructions for the handling, assembly and maintenance of all SSCs, Tools and Equipment within the supply

4.1.6 Shipment, Transportation and Delivery to the IO site

The components shall exclusively be delivered to the IO Site using the ITER Global Logistic Provider (DAHER) under the responsibility of the contractor.

Before the shipment, a Release Note shall be prepared in accordance with the “Contractor Release Note” [AD5] and approved by the IO.

Upon receipt of the package, the IO shall open the package and make a visual inspection of its content to check:

- The integrity of the package, including identifying visible damage;
- The number and type of components contained in the shipment;
- The enclosed documentation;
- The reading of the accelerometers or other sensors;
- The integrity of the components.

In the case of anomalies the IO shall make any additional relevant remark on the inspection.

The IO will inspect the accelerometers or other sensors mounted on the boxes. If these accelerometers record shocks above 5g, a thorough inspection of the components shall be performed. A decision on acceptance of the delivery of the components will be made by the IO.

If the components are in an acceptable condition, the IO will sign the Delivery Report. The signature of the Delivery Reports is an IO Hold Point.

The original of the Delivery Report shall be kept by the IO and a copy of it shall be kept by The contractor.

5 Testing

5.1 Examination, Inspection and Tests

All operations to be carried out by the contractor shall be listed in the MIPs which shall be submitted to the IO for approval. The inspection plan shall include the operations which will ensure that the requirements related to the following key aspects (not exhaustive) are satisfied:

- Specific dimension and tolerance to be controlled
- Surface finish conditions
- Cleanliness
- Alumina and Copper coating strength
- Tightening torque
- Connector assembly compliance to the drawing: use of correct sub-parts

ITER_D_9SFDTC

The contractor shall perform factory testing before shipping the components to the IO. For each milestone the contractor shall provide support necessary to test the component/system to demonstrate that the required performance meet the criteria.

5.2 Final Acceptance Test

5.2.1 Dimensional inspection

The contractor shall define the specific dimensions to control and submit to IO for approval. One of the dimension to be included is the distance of the centre of the ceramic insulator from the datum of the RH connector housing.

All the measuring instruments used for the inspection of the RH connectors shall be properly calibrated and records of the calibration shall be maintained.

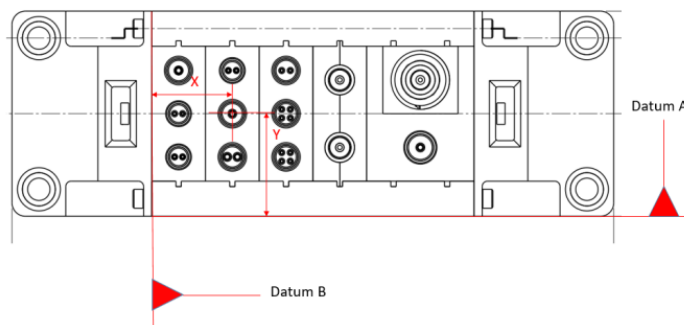

Figure 25 Dimensions (X, Y) to be inspected during FAT: the center of all the ceramic insulator shall be measured.

The dimension shall be consistent with the approved 2D drawings, which IO will provide.

5.2.2 Visual inspection

The contractor shall conduct the visual inspection for the assembled RH connectors for the following aspects, which may not include all the necessities:

- Surface condition: oxidation, strain, or marks
- Any crack and damage of the insulator
- Any damage of the contact pin and socket

Visual inspection shall be done as per approved procedure.

The acceptance criteria for visual inspection is as below:

- No oxidation of copper coating
- No damage of copper coating such as peel-off
- No strain, marks or residues on the surface of the connector
- No crack and damage of the ceramic insulator
- No damage of the contact pin and socket such as bending, peel-off of coating, etc.

ITER_D_9SFDTC

5.2.3 Electrical Tests

The following electrical tests shall be carried out according to EIA 364 or equivalent standards accepted by IO when the male and the female connector assembly is fully engaged:

- Continuity test
- Contact resistance test (resistance between both ends of the engaged contact pin & socket)
- Insulation resistance test for contact-to-contact (for the multi-pin connector) and contact-to-ground
- Withstand voltage test

For each type of MI cable to be connected, the acceptance criteria are specified in Table 3.

Table 3 Acceptance criteria for electrical test

MI cable type	Contact resistance [mΩ]	Insulation resistance [GΩ]	Withstand voltage [V]
MIC1	< 50	> 0.1	200V RMS @ 60Hz
MIC2	< 20	> 0.1	200V RMS @ 60Hz
MIC3 & MIC7	< 10	> 1	2000V RMS @ 60Hz
MIC4	< 10	> 1	1200V RMS @ 60Hz
MIC5	< 20	> 1	1200V RMS @ 60Hz
MIC6 & MIC8	< 20	> 1	2000V RMS @ 60Hz
MIC11	< 10	> 1	5000V RMS @ 60Hz

5.2.4 Mechanical test

The connector assemblies shall be tested for 1 engagement/release cycle. This test shall be carried out by considering the following misalignment between the male and the female part.

For the FE connector assembly,

- ± 1 mm along the poloidal and toroidal directions
- 1mm overrun in the axial direction

For the DSM connector assembly,

- ± 4 mm along the poloidal and toroidal directions
- 4 mm overrun in the axial direction

Connection and disconnection of the connector assemblies shall be conducted using a jig equipped with linear motion actuators and the force shall be recorded for all the connector assemblies.

After disengagement, the visual inspection shall be done to investigate any damage of the connector assemblies, especially the contact pin and socket. No damage shall be made during this test.

6 Contract Management

The contractor shall prepare a Project Execution Plan (PEP) to describe how the contractor intends to execute their works. It shall identify the Scope of work, the organisational structure proposed; key processes which will be carried out and roles and responsibilities within the

ITER_D_9SFDTC

Contract. The PEP shall be composed by a main document and other subsidiary plans as detachable documents: the Manufacturing and Inspection Plan (MIP), the Document Schedule, the Detailed Work Schedule (DWS), the Contract Risk Register and the Subcontracting Schedule.

6.1 Control Points

The IO shall ensure a close oversight of the production of its main Suppliers and Subcontractors in accordance with approved Manufacturing and Inspection Plans (MIP) [30], as detailed in Section 7. This monitoring shall include Control Points at critical steps in The contractors' plans. The control points shall be integrated into the agreed schedule.

A Notification Point (NP) is a milestone where The contractor is required to notify the IO, that it has completed a specific task or a specific deliverable and is proceeding to the next task or to the next action on the specific deliverable. A NP is meant to enable the IO personnel to follow the progress of the Contract and possibly to witness a critical manufacturing step at The contractor's premises. The Notification shall be sent by The contractor to the IO at least 10 working days prior to the scheduled manufacturing step. The IO shall decide whether or not they want to attend. A NP shall not affect the production flow of the contractor that shall continue the work even without a reply from the IO.

A Hold Point (HP) is a milestone where the contractor is required to notify the IO, that it has completed a specific task or a specific deliverable and must stop the associated processes until a HP Clearance is issued. The HP Clearance shall be issued on the basis of clearly identified Quality Control and data and Acceptance test results to be provided to the IO at the time of the request. The IO shall have a maximum of 5 working days to review the contractor's data and to notify the contractor of its decision. In case of clearance the contractor shall resume its activity. In case of rejection, the contractor shall develop a recovery plan that shall be submitted and reviewed by the IO within 10 working days of submission.

A Witness Point (W) is a milestone which identifies an operation to be witnessed. Adequate notice shall be given to the IO, in order to allow the IO to participate to the operation.

A Surveillance Point (S1) identifies an operation that requires 100% inspection.

A Surveillance Point (S2) identifies an operation that requires random inspection or spot checks.

Review (R) identifies a document or report to be reviewed.

6.2 Data Management

The data generated during the execution of the present Contract shall be handled electronically and entered into the ITER IDM (documents) and SMDD (2D drawings). The structure of this database shall be defined by the IO. The contractor shall use this database to store information related to the Contract. All data entered in the database will be kept strictly confidential by the IO and, under no circumstances, shall be communicated or made accessible to other Suppliers or the DAs. Data consistency checks shall be implemented to facilitate IO oversight. Relevant data shall be made available by the contractor to the IO through IDM each time a control point is

ITER_D_9SFDTC

requested, or a deviation request, a non-conformance report, or any other document which is part of the Contract deliverables is issued by the contractor, in accordance with the document “Procedure on Procurement Documentation Exchange between IO, DA, and contractors” [RD14]. This requirement does not apply for other documents and data files which are, for example, managed through specialized CAD software (e.g. CATIA) and so undergo other requirements specified in separate documents.

The manufacturing procedures shall be managed through IO MDB (Manufacturing DataBase) system after the MIP will be approved and transferred to the MDB by IO.

6.3 Reviews

The contractor will organise Design Review, Status Reviews (SRs), Quality Control Reviews (QCRs) and Manufacturing Readiness Reviews. These may be focused on particular areas of production. The IO may decide to organise the reviews, in which case the IO will appoint the review group and define its terms of reference.

The IO may decide to put a Hold Point on them.

6.4 Monitoring and Access Rights

The contractor shall submit periodic reports to the IO, with a frequency depending on the progress of the works. Progress meetings shall be conducted at the IO or contractor premises, as required by the IO.

The contractor shall ensure that access rights are granted to IO personnel at all locations where ITER work is being performed.

In case of concerns regarding the quality of production, the IO reserves the right to perform unscheduled inspections in accordance with Section 5.11 of the ITER Procurement Quality Requirements [AD3]. Planned and documented audits will be performed by the IO, and regulatory body representatives in France, to verify compliance with the technical and quality requirements of the Contract.

Moreover the IO reserves the right to take photographs of the ITER equipment during the contract life.

7 Quality Assurance

Quality Requirements shall be in accordance with the “ITER Procurement Quality Requirements” [AD3]. The ITER Quality Assurance Program shall be applied to all the work under this Contract. The contractor and subcontractors carrying out contracts placed under this Contract shall be in compliance with the QA requirements under the relevant ITER QA classifications and shall have an IO approved QA Program or an ISO 9001 accredited quality system, complemented with the above mentioned requirements.

Prior to commencement of any work under this Contract, a “Quality Plan” (QP) [AD4] shall be produced by the contractor and Subcontractors and submitted to the IO for approval, describing how they will implement the ITER Procurement Quality Requirements.

Prior to commencement of any manufacturing, a “Manufacturing and Inspection Plan” (MIP) [RD1] shall be produced by the contractor and Subcontractors and approved by the IO, who will mark up any intended intervention point. MIPs are used to monitor Quality Control and

ITER_D_9SFDTC

acceptance tests during the execution of the Contract. It should be noted that interventions additional to those required in this Technical Specification may be included on the MIP by the IO. The right of the IO listed above shall apply in relation to any Subcontractor and in this case the IO will operate through the contractor. The overseeing of the quality control operation by the IO shall not release the contractor from his responsibility in meeting any aspect of this Technical Specification.

Subcontractors not performing Critical Quality Activities (i.e. activities that if not performed correctly may affect safety, functionality or reliability) may be exempted from the requirement to supply Quality Plans and Manufacturing & Inspection Plans, subject to agreement by the IO.

All requirements of this Technical Specification and subsequent changes proposed by the contractor during the course of execution of this Contract are subject to the Deviation Request process described in “Contractors Deviations and Non-conformities Procedure” [AD6].

Documentation developed as the result of this Contract shall be retained by the contractor for a minimum of 5 years and then may be discarded at the direction of the IO. The use of computer software to perform a safety basis task activity such as analysis and/or modelling, etc. shall be reviewed and approved by the IO prior to its use, in accordance with “Quality Assurance for ITER Safety Codes Procedure” [RD16].

8 Applicable and reference documents

8.1 Applicable documents

This list contains documents that are mandatory.

- [AD1] ITER Vacuum Handbook (2EZ9UM v2.5)
- [AD2] General Management Specification for Service and Supply (82MXQK v1.4)
- [AD3] ITER Procurement Quality Requirements (22MFG4 v5.1)
- [AD4] Requirements for Producing a Quality Plan (22MFMW v4.0)
- [AD5] ITER Requirements Regarding Contractors Release Note (ITER_D_22F52F)
- [AD6] Procedure for Management of Nonconformities (22F53X v9.1)
- [AD7] APPENDIX B1_02: CAD & Design Activities Management for RH Connectors (7TV3ZM v1.0)

8.2 Reference documents

This list contains documents for information:

- [RD1] Work Instruction for Producing of the Manufacturing and Inspection Plan (UKQG8M v1.6)
- [RD2] Working Instruction for Manufacturing Readiness Review (44SZYP v5.0)
- [RD3] Appendix A, Materials Design Limit Data (222RLN v3.3)
- [RD4] Appendix 3 Materials (27Y4QC v1.20)
- [RD5] Appendix 4 Accepted Fluids (2ELN8N v1.14)
- [RD6] Appendix 13 Cleaning and Cleanliness (2ELUQH v1.2)
- [RD7] Appendix 14 Passivation and Pickling (2F457S v1.2)

ITER_D_9SFDTC

- [RD8] ITER Vacuum Handbook Attachment 2 - Cleanliness Requirements Relating to the Assembly of Vacuum Equipment (MBXPP3 v1.7)
- [RD9] Codes and Standards for ITER Mechanical Components (25EW4K v4.0)
- [RD10] Safety Important Functions and Components Classification Criteria and Methodology (347SF3 v1.8)
- [RD11] Quality Classification Determination (24VQES v5.2)
- [RD12] ITER Site Signage & Graphics Standards (4ALJEU v2.5)
- [RD13] ITER Numbering System for Components and Parts (28QDBS v5.0)
- [RD14] IO/DA Documentation Exchange and Storage (35BVQR v5.0)
- [RD15] MDB Manual IDM folder (<https://user.iter.org/?uid=T6VPEP>)
- [RD16] Working Instruction for the Qualification of ITER safety codes (258LKL v3.1)
- [RD17] Appendix A Material Design Limit Data (222RLN v3.3)

9 Acronyms

The meanings of the main acronyms included in this report are:

- CAD: Computer Assisted Design
- DA: Domestic Agency
- DSM: Diagnostic Shielding Module
- DR: Deviation Request
- EOM: End-Of-Manufacturing
- FE: Front End
- FAT: Factory Acceptance Tests
- HP: Hold Point
- IO: ITER Organization
- LEVI: Loom Electrical Vacuum Interface
- LEF: LEVI Electrical Feedthrough
- MDB: Manufacturing Data Base
- MIP: Manufacturing and Inspection Plan
- MRR: manufacturing Readiness Review
- NC: Non- Conformance
- NDT: Non Destructive Testing
- NP: Notification Point
- PEP: Project Execution Plan
- PP: Port Plugs
- QC: Quality Class
- R: Review of document point
- RH: Remote Handling
- S: Surveillance point
- SIC: Safety Important Component
- UHV: Ultra High Vacuum
- UT: Ultrasonic Testing
- VQC: Vacuum Class
- VV: Vacuum Vessel
- W: Witness point
- WP: Work Package

For a complete list of ITER abbreviations see: [ITER Abbreviations \(ITER_D_2MU6W5\)](#).

10 List of Appendices

- Appendix 1: Bill of Material
- Appendix 2: List of documents and data to be provided by the contractor (List of Deliverables)
- Appendix 3: Compliance matrix between Connector Modules and the cable types

Appendix 1. Bill of Material (BOM)

Table 4 BOM of standard sub-parts for the FE/DSM connector assemblies

(It should be noted that for the SS casings (No. 1 ~ 8) and the modules (No. 9~21) the single unit of the quantity is composed of a coupled pair of a male part and a female part, while the quantity of the insulator assembly (No. 22 ~ 43) is calculated for each type of male or female part separately)

No	Components	Part ID	Drawing No.		Quantity				
					Batch#1 (EPP#11/12)	Batch#2 (UP2/4/5/6/7/8/18 & EP2/8/17)	Batch#3 (UP9/11/14 & EP3/9)	Spares	Total
1	SS Casing for FE Con. with 1 Module	FE-1M	Male	to be updated	6	23	13	4	46
			Female	068621					
2	SS Casing for FE Con. with 2 Modules	FE-2M	Male	to be updated	6	9	4	3	22
			Female	070235					
3	SS Casing for FE Con. with 3 Modules	FE-3M	Male	to be updated	3	3	0	1	7
			Female	070253					
4	SS Casing for FE Con. with 4 Modules	FE-4M	Male	to be updated	0	2	3	1	6
			Female	to be updated					
5	SS Casing for FE Con. with 5 Modules	FE-5M	Male	to be updated	4	8	6	2	20
			Female	070261					
6	SS Casing for FE Con. with 6 Modules	FE-6M	Male	to be updated	3	7	11	3	24
			Female	068638					
7	SS Casing for DSM Con. with 5 modules	DSM-5M	Male	070257	3	13	4	2	22
			Female	070636					
8	SS Casing for DSM Con. with 11 module	DSM-11M	Male	068199	5	8	8	2	23
			Female	067996					
9	Module-A1	M-A1	Male	063460	21	53	70	16	160
			Female	063447					
10	Module-A2	M-A2	Male	063463	29	0	0	6	35

ITER_D_9SFDTC v1.0

			Female	063402					
11	Module-A3	M-A3	Male	063553	0	3	0	2	5
			Female	063393					
12	Module-A4	M-A4	Male	063558	1	9	19	6	35
			Female	063400					
13	Module-A5	M-A5	Male	to be updated	1	4	2	3	10
			Female	to be updated					
14	Module-A6	M-A6	Male	to be updated	6	0	0	4	10
			Female	to be updated					
15	Module-A7	M-A7	Male	to be updated	3	22	18	7	50
			Female	to be updated					
16	Module-A8	M-A8	Male	063584	0	23	0	2	25
			Female	063409					
17	Module-B1	M-B1	Male	063605	22	89	65	14	190
			Female	063440					
18	Module-B2	M-B2	Male	063606	26	6	9	9	50
			Female	063441					
19	Module-B5	M-B5	Male	063608	1	4	2	3	10
			Female	063616					
20	Module-B7	M-B7	Male	063609	3	22	18	7	50
			Female	063631					
21	Module-B8	M-B8	Male	063607	0	11	0	4	15
			Female	to be updated					
22	Male insulator Assembly for MIC1	IM-M1		063423	100	319	324	87	830
23	DSM Female Insulator Assembly for MIC1	IF-M1-DSM		063413	56	177	171	46	450
24	FE Female Insulator Assembly for MIC1	IF-M1-FE		063769	44	142	153	41	380
25	Male insulator Assembly for MIC2	IM-M2		063425	18	40	68	24	150
26	DSM Female Insulator Assembly for MIC2	IF-M2-DSM		063417	12	20	34	14	80

ITER_D_9SFDTC v1.0

27	FE Female Insulator Assembly for MIC2	IF-M2-FE	063770	12	20	34	14	80
28	FE Male insulator for H-Alpha system for MIC2	IF-M2-FE-E2	063854	6	0	0	4	10
29	Male insulator Assembly for MIC3/MIC7	IM-M3M7	063427	4	0	0	6	10
30	DSM Female Insulator Assembly for MIC3/MIC7	IF-M3M7-DSM	063418	2	0	0	8	10
31	FE Female Insulator Assembly for MIC3/MIC7	IF-M3M7-FE	063672	2	0	0	8	10
32	Male insulator Assembly for MIC4	IM-M4	063428	0	24	52	14	90
33	DSM Female Insulator Assembly for MIC4	IF-M4-DSM	063419	0	12	26	12	50
34	FE Female Insulator Assembly for MIC4	IF-M4-FE	063671	0	12	26	12	50
35	Male insulator Assembly for MIC5	IM-M5	063431	18	8	14	10	50
36	DSM Female Insulator Assembly for MIC5	IF-M5-DSM	063420	9	4	7	10	30
37	FE Female Insulator Assembly for MIC5	IF-M5-FE	063772	9	4	7	10	30
38	Male insulator Assembly for MIC6/MIC8	IM-M6/8	063753	104	2	0	24	130
39	DSM Female Insulator Assembly for MIC6/MIC8	IF-M6/8-DSM	063421	58	1	0	11	70
40	FE Female Insulator Assembly for MIC6/MIC8	IF-M6/8-FE	063511	58	1	0	11	70
41	FE Male insulator for H-Alpha system fir MIC6/MIC8	IF-M6/8-FE-E2	063859	12	0	0	8	20
42	Male insulator Assembly for MIC11	IM-M11	063716	2	8	4	6	20
43	Female Insulator Assembly for MIC11	IF-M11	063717	2	8	4	6	20

Table 5 BOM of FE/DSM connector assemblies for Batch#1

No.	Port No.	Connector Assembly	PNI	Drawing No.	Quantity
1	EP12	DSM MALE CONNECTOR ASSY_1_11 Modules	I004Q4VM7	068197	1
2	EP12	DSM MALE CONNECTOR ASSY_2_11 Modules	I004AWA3S	068192	1
3	EP12	DSM MALE CONNECTOR ASSY_3_11 Modules	I004EJQDX	068627	1
4	EP12	DSM MALE CONNECTOR ASSY_4_11 Modules	I004EJQEJ	070352	1
5	EP12	DSM MALE CONNECTOR ASSY_5_11 Modules	I004L5RF7	070299	1
6	EP12	DSM FEMALE CONNECTOR ASSY_1_11 Modules	I003GMHKP	068087	1
7	EP12	DSM FEMALE CONNECTOR ASSY_2_11 Modules	I003GGWEC	068217	1
8	EP12	DSM FEMALE CONNECTOR ASSY_3_11 Modules	I003GMQV2	068202	1
9	EP12	DSM FEMALE CONNECTOR ASSY_4_11 Modules	I003GGVSV	068238	1
10	EP12	DSM FEMALE CONNECTOR ASSY_5_11 Modules	I003GGUL2	068292	1
12	EP12	FE FEMALE CONNECTOR ASSY_6 Modules	I002VYGSS	068598	1
13	EP12	FE FEMALE CONNECTOR ASSY_2 Modules	I0034LF7V	070271	1
14	EP12	FE FEMALE CONNECTOR ASSY_1 Modules	I0034LCPE	068624	1
15	EP12	FE FEMALE CONNECTOR ASSY_2 Modules	I0034LF9W	068593	1
16	EP12	FE FEMALE CONNECTOR ASSY_6 Modules	I003ERLJ2	068637	1
17	EP12	FE FEMALE CONNECTOR ASSY_1 Modules	I004V562X	070085	2
18	EP12	FE FEMALE CONNECTOR ASSY_6 Modules	I006LGDKZ	068601	1
19	EP12	FE FEMALE CONNECTOR ASSY_5 Modules	I002ZZTBZ	070260	4
20	EP12	FE FEMALE CONNECTOR ASSY_2 Modules	I002ZZZ3N	070234	1
21	EP12	FE FEMALE CONNECTOR ASSY_3 Modules	I002ZZTD2	070252	2
22	EP12	FE FEMALE CONNECTOR ASSY_2 Modules	I002TQ3KY	070355	1
23	EP12	FE FEMALE CONNECTOR ASSY_3 Modules	I002TQ3KY	070357	1
24	EP12	FE FEMALE CONNECTOR ASSY_1 Modules	I002VSGBS	070358	1
25	EP11	DSM_FEMALE_CONNECTOR_ASSY_1_5 Modules	I0056VRDK	070558	1

ITER_D_9SFDTC v1.0

26	EP11	DSM_FEMALE_CONNECTOR_ASSY_2_5 Modules	I0056VRFN	070552	1
27	EP11	DSM_FEMALE_CONNECTOR_ASSY_3_5 Modules	I0056VRG5	070555	1
28	EP11	DSM_MALE_CONNECTOR_ASSY_1_5 Modules	I0057DKF5	070254	1
29	EP11	DSM_MALE_CONNECTOR_ASSY_2_5 Modules	I0055938R	070276	1
30	EP11	DSM_MALE_CONNECTOR_ASSY_3_5 Modules	I0057E7DB	070286	1
31	EP11	FE FEMALE CONNECTOR ASSY_2 Modules	I0034EY2A	070360	2
32	EP11	FE FEMALE CONNECTOR ASSY_1 Modules	I0034EY49	070263	2

Appendix 2 : List of documents and data to be provided by the contractor (List of Deliverables)

The documents which the contractor shall provide as deliverables are listed in the table below. T0 means the Kick-off meeting date.

Table 6 List of deliverables and the due dates

D #	Description	Due Dates
D01	P#01/#02/#03/#04/#05 in Table 7	T0 + 1 months
D02	P#8/#9/#10/#11/#12 in Table 7	T0 + 3 months
D03	MRR execution & closure (Presentation) *IO will prepare agenda, notification and input package list.	T0 + 4 months
D04	P#13/#14/#15 in Table 7 for 1 st batch of in-series product	T0 + 8 months
D05	P#16/#17/#18/#19 in Table 7 and supply of 1 st batch of in-series product	T0 + 9 months
D06	Completion of sub-parts manufacturing for Batch#2	T0 + 18 months
D07	P#13/#15 in Table 7 for 2 nd batch of in-series product	T0 + 27 months
D08	P#18/#19 in Table 7 and supply of 2 nd batch of in-series product	T0 + 31 months
D09	Completion of sub-parts manufacturing for Batch#3	T0 + 34 months
D10	P#13/#15 in Table 7 for 3 rd batch of in-series product	T0 + 42 months
D11	P#18/#19 in Table 7 and supply of 3 rd batch of in-series product	T0 + 48 months

The following table summarizes the different documents that shall be provided by the contractor.

Table 7 Documents to be delivered

Documents to be delivered	Content	Need date
P#01 Quality Plan	As per Section 7	KOM
P#02 Project	As per Section 6	KOM

Execution Plan		
P#03 Contract risk register	plan for managing risks associated with implementing the Contract	KOM
P#04 Detailed Work Schedule (DWS), including documentation schedule	The schedule should be in the form of a fully resourced program based on the Work Breakdown Structure (e.g. Primavera, MS Project), identifying all significant milestones, documentations, deliverables, activities, and their interdependencies, durations and anticipated start and finish dates and the project critical path(s). The detailed schedule proposed at the official Kick-off Meeting by the Contractor, once agreed, will be used as baseline.	KOM
P#05 Verification control plan	The verification control plan shall consist of a compliance matrix listing all requirement (RQ) listed in this specification.	KOM
P#06 Monthly Progress Report	Report of technical progress and issues to be presented at monthly progress meeting. The progress (%) update as per DWS must to be provided as well. (IO will provide a template for progress update)	Monthly
P#07 Meeting minutes	Meeting minutes for Kick-Off meeting and monthly progress meeting, including ad-hoc meetings.	For each meeting
P#8 MIP	As per Section 3.7	MRR
P#9 3D model /2D Drawings	Built-to-Print drawings including manufacturing drawings	MRR
P#10 Fabrication specification	The Fabrication Specification is a complementary document of the MIP, giving more details on the operations listed in the MIP and providing links to further specifications or procedures as required for each operation (machining, coating, assembly, surface inspection, cleaning, marking, etc). The document also describes all of the tests or inspections to be performed during the manufacturing.	MRR
P#11 Clean work plan	The Clean Work Plan shall specify how cleanliness will be maintained throughout the manufacturing process. It shall state when specific cleaning procedures will be applied and all of the controls which will be in place to maintain cleanliness including handling.	MRR
P#12 Coating qualification results	Report for Cu and Alumina coating qualification test as per Section 3.7.4 and 3.7.5, respectively	MRR
P#13 Material certificates	Per material	FAT
P#14 FAT plan	Test procedures for factory acceptance as per Section 5.2	FAT
P#15 FAT results	Report for the FAT results and acceptance certificate	FAT

report	per each batch	
P#16 Handling and packing plan	The handling and packing plan shall state how to store, preserve, handle and pack the final product for shipping (Section 4.1.5)	DRR
P#17 Transportation Quality Plan	As per Section 10.3 in [AD2]	DRR
P#18 Delivery report	As per Section 4 per each batch	DRR
P#19 Contractor's Release Note	As per [AD5] per each batch	DRR

Appendix 3. Compliance matrix between Connector Modules and the cable types

(Please note that the dimensions given here should not be taken as reference. All the dimensions should be taken from the 2D drawings provided by IO)

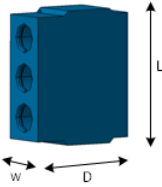
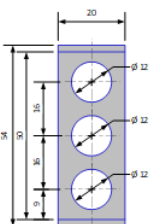
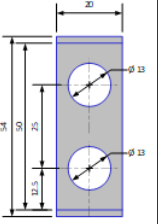
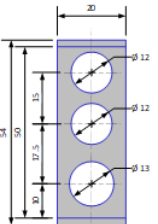
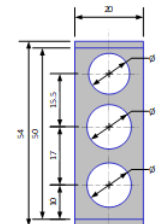
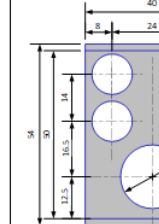
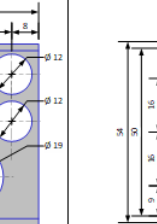
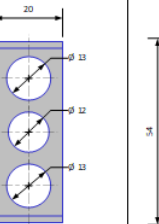
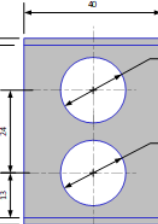
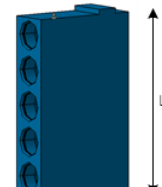
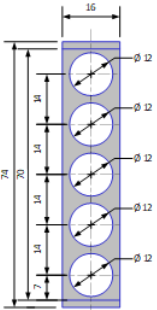
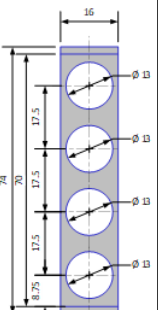
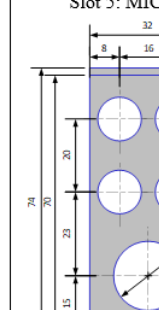
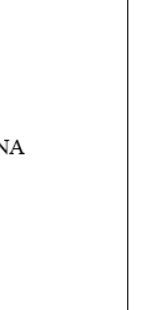
Arrangement / Module Size	Arrangement 1	Arrangement 2	Arrangement 3	Arrangement 4	Arrangement 5	Arrangement 6	Arrangement 7	Arrangement 8
<p>Module type A</p>  <p>Fit to the FRONT-END Connector</p>	<p>Module A1 Can fit 3 cables (MIC#1, MIC#2)</p> 	<p>Module A2 Can fit 2 cables (MIC#3 to MIC#8)</p> 	<p>Module A3 Can fit 3 cables Slot 1,2: MIC#1, #2 Slot 3: MIC#3 to #8</p> 	<p>Module A4 Can fit 3 cables Slot 1: MIC#1, #2 Slot 2,3: MIC#3 to #8</p> 	<p>Module A5 Can fit 5 cables GDC Module Slot 1 to 4: MIC#1, Slot 5: MIC#11</p> 	<p>Module A6 Can fit 3 cables Slot 1, 3: MIC#3 to MIC#8 Slot 2: MIC#1, MIC#2</p> 	<p>Module A7 Can fit 2 cables Slot 1, 2: MIC#9</p> 	<p>Module A8 Can fit 2 cables Slot 1, 2: MIC#10</p> 
<p>Module type B</p>  <p>Fit to the DSM Connector</p>	<p>Module B1 Can fit 5 cables (MIC#1, MIC#2)</p> 	<p>Module B2 Can fit 4 cables (MIC#3 to #8)</p> 	<p>NA</p>	<p>NA</p>	<p>Module B5 Can fit 5 cables GDC Module Slot 1 to 4: MIC#1, Slot 5: MIC#11</p> 	<p>NA</p>	<p>Module B7 Can fit 2 cables (MIC#9)</p> 	<p>Module B8 Can fit 4 cables (MIC#10)</p> 